

ACCUVAC Pro/ACCUVAC Lite

Suction device

Instructions for Use



Designed by:

WEINMANN Emergency Medical Technology GmbH + Co. KG

Frohbösestrasse 12

22525 Hamburg

GERMANY

E: kundenservice@weinmann-emt.de

www.weinmann-emergency.com

T: +49 40 88 18 96-120

F: +49 40 88 18 96-481

Manufacturer:

ATMOS MedizinTechnik GmbH & Co. KG

Ludwig-Kegel-Straße 16

79853 Lenzkirch

GERMANY

CE 0124

Contents

1	Introduction	5
1.1	About this document	5
1.2	Explanation of warning notices	5
1.3	Function	6
2	Safety	8
2.1	Intended purpose	8
2.2	Safety information	11
2.3	General instructions	17
3	Description	19
3.1	Overview	19
3.2	Control panel	21
3.3	Accessories	23
3.4	Other parts	27
3.5	Labels	28
4	Preparation and operation	32
4.1	Assembling the device	32
4.2	Connecting to a power supply	32
4.3	Using the rechargeable battery	33
4.4	Connecting parts	42
4.5	Connecting accessories and other parts	55
4.6	Switching on the device	61
4.7	Switching off the device	62
4.8	Performing suction	62
4.9	Emptying the canister system	65
4.10	Changing the canister system	71
4.11	Transporting the device	72
4.12	After use	73
5	Hygienic reprocessing	74
5.1	General instructions	74
5.2	Intervals	74

5.3	Hygienic reprocessing of the device	75
5.4	Removing the device base	81
5.5	Hygienic reprocessing of the reusable canister system	82
5.6	Hygienic reprocessing of the disposable canister system	86
6	Function check	89
6.1	Intervals	89
6.2	Performing a function check	89
7	Faults	94
7.1	Device	94
7.2	Power supply unit and charger	97
8	Maintenance	98
8.1	General instructions	98
8.2	Sending parts for inspection and repair	98
8.3	Changing the release catch	99
8.4	Replacing the cap for adjusting knob of the vacuum regulator	100
9	Storage	101
9.1	General instructions	101
9.2	Storing the device	101
10	Disposal	102
10.1	Electronic waste	102
10.2	Battery	102
10.3	Reusable canister system	102
10.4	Disposable canister system	103
10.5	Suction material	103
10.6	Bags/cases	103
10.7	Contaminated parts	103
11	Appendix	104
11.1	Technical data	104
11.2	Scope of supply	110
11.3	Warranty	122
11.4	Declaration of conformity	122

1 Introduction

1.1 About this document

This document describes all possible versions of the device.

Functions, accessories and other parts which are described in this document or shown in the images depend on the version purchased and are not always available.

Diagrams in these instructions for use serve to improve basic understanding and may differ from the actual design. No claims can be derived from any deviations.

1.2 Explanation of warning notices

Warnings are used to flag up safety-relevant information.

You will find a warning preceding any action that entails a hazard for persons or equipment.

Warnings consist of

- the warning symbol (pictogram),
- a signal word designating the hazard level,
- information about the hazard and
- instructions for avoiding the hazard.

The warnings appear in three hazard levels depending on the degree of danger:



Danger!

Designates an extremely dangerous situation. Failure to observe this warning will lead to serious, irreversible injury or death.



Warning!

Designates an extremely dangerous situation. Failure to observe this warning may lead to serious, irreversible or fatal injury.



Caution!

Designates a dangerous situation. Failure to observe this warning may lead to minor or moderately serious injury.



Notice!

Indicates a hazardous situation. Failure to observe this warning may lead to damage to equipment.



Designates useful information relating to a particular action.

1.3 Function

1.3.1 Device

The device is operated with a battery or an external 12 V DC power source (12 V connection cable or power supply unit and charger). During suction, a vacuum pump in the device generates a vacuum in the hoses/tubes and the canister system. This vacuum suctions the suction material (e.g., secretions, blood, bodily fluids, or food particles) into the canister system. The vacuum can be regulated.

1.3.2 Reusable canister system

The reusable canister system is stored on the side of the device in the holder for reusable canister system and is connected directly to the device inlet. The suction material is conveyed to the reusable secretions canister via a reusable suction hose. A float ball and a hydrophobic bacteria filter in the secretions canister cover prevent bacteria and the suction material from entering the device. The float ball floats on the surface of the suction material until it blocks the outlet. The hydrophobic bacteria filter also filters contaminated air and seals off the pores if they become wetted with droplets.

1.3.3 Disposable canister system

The disposable canister system is stored on the side of the device in the holder for disposable canister system and is connected to the device inlet via the vacuum tube. The disposable canister system contains a Serres suction bag with integrated bacteria filter, which prevents the suction material from entering the device. The suction material is conveyed to the Serres suction bag via a disposable suction hose. The disposable suction hose and Serres suction bag are single-use devices and should be disposed of after use.

2 Safety

The instructions for use form part of the device. If the instructions for use and the following safety information are not fully complied with, the treatment may fail or be compromised. This could cause severe or life-threatening injuries to the patient, user or bystanders.

- ⇒ Fully comply with the instructions for use.
- ⇒ Keep the instructions for use with the device so that they can be accessed at any time.
- ⇒ Only use the device as defined by the intended use (see „1.3 Function“, page 6).
- ⇒ Do not use the device in the event of contraindications.
- ⇒ Observe the instructions for use of the accessories and other parts.

Any serious incident that has occurred in relation to the device should be reported to the manufacturer and the competent authority of the Member State.

2.1 Intended purpose

Designation	Description
Main functions:	<p>Temporary and spontaneous suction of secretions, blood, serous fluids and bodily fluids as well as low-viscosity, viscous, and solid food particles from the oral cavity, pharynx and bronchial system</p> <p>For deflating vacuum mattresses and vacuum splints</p>
Intended use:	Suctioning the upper and lower airways
Intended users/user profiles:	<ul style="list-style-type: none"> • Physicians • Medical personnel • EMS field providers • Non-medical users, e.g. patients and/or relatives (after receiving instruction in the use of the device from a medical professional)

Designation	Description
User training:	The device must only be used by persons who possess a medical qualification or have received training in the suction technique from a physician.
Intended patient target groups:	Patients of all age groups with and without restrictions
Medical condition to be diagnosed, treated, or monitored:	Not applicable
Organ to be treated:	<ul style="list-style-type: none"> • Upper airways (nose, nasal cavity, pharynx) • Lower airways (larynx, trachea, bronchial system)
Duration of use:	Temporary application on the patient (< 60 mins).
Application environment:	<ul style="list-style-type: none"> • Clinical, office-based, emergency medical, nursing, and home-based settings • Use in emergency situations • Use outdoors and during transportation
Criteria for patient selection:	Patients who would benefit from suctioning the upper and/or lower airways
Indications:	<ul style="list-style-type: none"> • Suction of blood, secretions and food particles from the oral cavity, pharynx area and bronchial system • Suction in cases of muscular and/or neurological disorders: <ul style="list-style-type: none"> - Suction in cases of swallowing disorders • In cases of damage to respiratory and cough function with disorder of tracheal, bronchial or oral secretion elimination: <ul style="list-style-type: none"> - Suction during tracheotomy - Suction during laryngectomy - Suction in cases of obstruction of respiratory function
Medical contraindications:	<p>Not suitable for:</p> <ul style="list-style-type: none"> • Continuous operation when carrying out drainage in the low-vacuum range (e.g. thoracic drains or wound drains) • Long-term endoscopic applications • Vacuum extraction • Smoke extraction • Liposuction

Designation	Description
Further contraindications:	Not suitable for: <ul style="list-style-type: none"> • Suction of flammable, caustic or explosive substances • Suction in areas where there is a risk of explosion • Suction in medical areas where potential equalization is required (e.g. cardiac surgery) • Suction in non-medical fields
Adverse side-effects:	The following complications may arise during suction: <ul style="list-style-type: none"> • Bleeding in the nasopharynx • Vocal chord injuries • Tracheal injuries • Hypoxemia • Cardiovascular instability • Bradycardia, arrhythmia, and asystole (provoked by vagus nerve stimulation) • Tachycardia (provoked by stress) • Gagging, nausea, vomiting, and coughing • Hospital-acquired infection (HAI) of the airways • Seizures in patients who are susceptible to seizures
Warnings:	See chapter 2.2 „Safety information” in the current instructions for use for the product.
The product is:	<input checked="" type="checkbox"/> active <input type="checkbox"/> not active
Sterility / specific microbial state:	Not a sterile product
Disposable product/reprocessing:	The device is intended for multiple use. The device and some accessories can be reused. For information on reprocessing, cleaning and disinfection, see instructions for use.

2.2 Safety information

2.2.1 Qualification

Warning

Risk of injury due to lack of knowledge and failure to follow procedure!

The use of the device by users without medical qualifications and training in suction and/or the failure to follow procedure can result in serious injury to or death of the patient.

- ⇒ Only use the device if the user has a medical qualification or is familiar with suction and the operation of the device.
- ⇒ Only use the device if the user has been trained in the suction technique by a physician and is familiar with suction and the operation of the device.
- ⇒ Observe national and regional provisions and organizational procedure on suction.

2.2.2 How to use the device

Warning

Risk of explosion or fire from using the device in explosive atmospheres or areas enriched with oxygen!

Sparks caused by the vacuum pump in the device can ignite gas mixtures and consequently injure the patient and user and damage the device.

- ⇒ Do not operate the device in explosive atmospheres or areas enriched with oxygen.

Risk of injury from damaged device or power-supplying accessories!

A damaged device or damaged power-supplying accessories can trigger an electric shock and injure the patient or user.

- ⇒ Check the device and power-supplying accessories for damage before every use.
- ⇒ Replace damaged parts.
- ⇒ Do not use damaged devices or accessories.
- ⇒ If the device fails the function check: Do not use the device.
- ⇒ If the device is dropped or falls: Do not use the damaged device.

Risk of injury due to long hoses, tubes and power cords!

Children can strangle themselves with long hoses and/or tubes.

- ⇒ Keep hoses, tubes and power cords out of the reach of children.

Risk of injury from swallowable small parts!

Children can inhale small parts and injure themselves.

⇒ Keep swallowable small parts out of the reach of children.

Risk of injury due to inaccessible device!

During use, the device requires the intervention of the user. An inaccessible device may delay treatment and result in injury to the patient.

⇒ Position the device so that displays are clearly visible during use.

⇒ Keep the device accessible at all times.

Risk of injury due to reuse of disposables!

Disposables are intended for single use. Disposable which are reused may be contaminated and/or impaired in their function and therefore cause injury to the patient.

⇒ Do not reuse disposables.

Risk of injury due to missing, flat, or defective battery!

A missing, flat, or defective battery inhibits the therapy and can injure the patient.

⇒ Only operate the device with a charged battery.

Risk of injury from unapproved accessories!

Accessories which are not approved can interfere with the functioning of the device and injure the patient.

⇒ Only use the accessories listed in these instructions for use.

*Caution***Risk of injury due to liquids in the device!**

Liquids in the device can trigger an electric shock and consequently injure the patient and user and damage the device.

⇒ Disconnect the device from the power supply before starting the hygienic reprocessing.

⇒ Do not immerse the device in liquids.

⇒ If liquids have entered the device: Contact a technician authorized by ATMOS MedizinTechnik GmbH & Co. KG.

⇒ Do not rinse off the device and power-supplying accessories under running water.

⇒ Do not wipe the device and power-supplying accessories with a wet cloth.

⇒ Do not immerse the device and power-supplying accessories in disinfectant.

Risk of injury due to interference caused by electric and magnetic fields!

Electric and magnetic fields may interfere with the functioning of the device and injure the patient.

- ⇒ Maintain separation distances between the device and mobile telephones, radio units and X-ray apparatus.
- ⇒ Do not use the device in the vicinity of MRI devices.

Notice

Material damage due to operation of the device following transport at temperatures outside of the specified transport temperatures!

Operating the device directly after transport at temperatures outside of the specified transport temperatures can damage the device.

- ⇒ Store the device at operating temperature for 6 hours before using it.

Material damage if the battery is not handled properly!

Failure to handle the battery properly can destroy it.

- ⇒ Charge battery in good time.
- ⇒ Always charge battery for storage.

Material damage due to switching on the device with an existing vacuum of -0.8 bar!

If the device is switched on with an existing vacuum of -0.8 bar, the device may be damaged.

- ⇒ Do not switch on the device with a maximum vacuum of -0.8 bar.

2.2.3 Safe use of the power supply

Warning

Risk of injury if the power supply unit and charger are used in damp or electrically conductive surroundings!

Using the device in damp or electrically conductive surroundings may result in an electric shock and injure the patient and user.

- ⇒ Only use the power supply unit and charger in a dry place.
- ⇒ Only use the power supply unit and charger in surroundings that are not electrically conductive.

Risk of injury if the power supply unit and charger are not handled properly!

Failure to handle the power supply unit and charger properly can result in an electric shock and injure the user.

- ⇒ Observe the general safety provisions for working with electrical equipment.
- ⇒ Always grip the power plug and not the cable to pull it out of the socket.
- ⇒ Only ever use an undamaged power supply unit and charger.
- ⇒ Only have the power supply unit and charger repaired by ATMOS MedizinTechnik GmbH & Co. KG or a technician authorized by ATMOS MedizinTechnik GmbH & Co. KG.

Treatment prevented by defective power-supplying accessories!

Defective power-supplying accessories prevent the battery from charging and thus impair the operational readiness of the device.

- ⇒ Inspect the power-supplying accessories regularly.

Caution

Risk of injury due to trailing power cord!

A trailing power cord is a trip hazard, which may cause injury and interrupt operation of the device being used.

- ⇒ During line operation, position the power cord so that there is no danger of tripping over it.
- ⇒ During 12 V operation, position the connection cable so that there is no danger of tripping over it.

Risk of injury due to inaccessible power plug!

An obstructed power plug cannot be pulled out in an emergency and can thus result in injury.

⇒ Keep the power plug and line power accessible at all times.

Notice

Damaged electronics due to incorrect voltage or frequency of the power supply!

Incorrect voltage or frequency of the power supply can damage the electronics of the device.

⇒ Only connect the device with the WM 2620 power supply unit and charger to a line power with the correct line voltage and frequency.

⇒ Only connect the device to a 12 V DC power source with a WM 10650 12 volt connection cable.

2.2.4 Suction

Warning

Risk of asphyxia if device is used which is not ready for use!

Devices which are not ready for use impede suction and can result in serious injury to or death of the patient.

⇒ Keep an alternative means of suction available at all times.

⇒ Ensure that the correct hoses in accordance with the manufacturer's specifications are used with the disposable canister system.

⇒ Keep the device ready for use at all times.

⇒ Always store the device with the battery charged.

⇒ Perform a function check before and after every use.

⇒ If the device is not used: Perform a function check every 6 months.

Risk of asphyxia if the device fails or switches itself off during suction!

Devices which fail or switch themselves off impede suction and can result in serious injury to or death of the patient.

⇒ Keep an alternative means of suction available at all times.

⇒ Do not use the device in short-term operation for longer than 60 minutes (ACCUVAC Pro) or 45 minutes (ACCUVAC Lite).

⇒ Check the battery status repeatedly and charge the battery if necessary.

Risk of injury due to vacuum which is too high!

Too high a vacuum can damage the patient's tissue.

⇒ Adapt the vacuum to suit the patient.

⇒ Observe the applicable guidelines.

Risk of infection due to contaminated parts and suction material!

The device, the accessories and other parts can be contaminated by the suction material and infect the patient or user with bacteria or viruses.

⇒ Always wear suitable gloves.

⇒ Do not sterilize the device.

⇒ Only use sterile packed articles if the packaging is undamaged.

⇒ Only use the reusable canister system with a hydrophobic bacteria filter.

Risk of explosion or fire from suction of explosive, flammable, or caustic gases or liquids!

Sparks caused by the vacuum pump in the device can ignite gas mixtures and liquids and consequently injure the patient and user.

⇒ Do not suction any explosive, flammable, or caustic gases or liquids.

⇒ Observe the intended purpose.

Caution

Risk of injury if disposable canister system is not vertical during suction!

If the disposable canister system is not vertical during suction, the suction material can run into the integrated bacteria filter of the Serres suction bag and block the bacteria filter. This reduces suction capacity and can result in injury to the patient.

⇒ Always stand the device with disposable canister system upright on a solid surface during suction.

⇒ If suction material enters the bacteria filter: Replace the Serres suction bag.

Notice **Material damage if reusable canister system is not vertical during suction!**

If the reusable canister system is not kept vertical, the suction material can enter the device and damage the vacuum pump.

⇒ Always stand the device with reusable canister system upright on a solid surface during suction.

2.3 General instructions

- If third-party items are used, malfunctions may occur and fitness for use may be restricted. Biocompatibility may also be compromised. Please note that in such cases, any warranty claim and liability will be voided if neither the accessories recommended in the instructions for use nor original spare parts are used. Third-party items may increase the radiation output or reduce the interference immunity.
- Repairs, servicing, and maintenance should only be carried out by ATMOS MedizinTechnik GmbH & Co. KG or by a technician expressly authorized by ATMOS MedizinTechnik GmbH & Co. KG.
- The manufacturer guarantees the compatibility of the device with all approved accessories and other parts. Only have modifications to the device carried out by ATMOS MedizinTechnik GmbH & Co. KG or by a technician expressly authorized by ATMOS MedizinTechnik GmbH & Co. KG. Do not use any articles from third parties.
- Any constructive changes made to the device may put the patient and the user at risk and are not permitted.
- Please observe the section on hygienic reprocessing in order to avoid infection or bacterial contamination (see „5 Hygienic reprocessing“, page 74).
- Also observe the respective instructions for use for the accessories and the other parts.
- Observe the ambient conditions for operation, charging, transportation, and storage of the device (see „11.1 Technical data“, page 104).

- Always carry out a function check before using the device (see „6 Function check“, page 89).
- Do not operate the device if you identify damage. Clean the device and send it to WEINMANN Emergency, authorized by ATMOS MedizinTechnik GmbH & Co. KG, or another authorized technician for repair.
- Before deflating vacuum mattresses, check the connection compatibility with the adapter for vacuum mattresses (not included).

3 Description

3.1 Overview

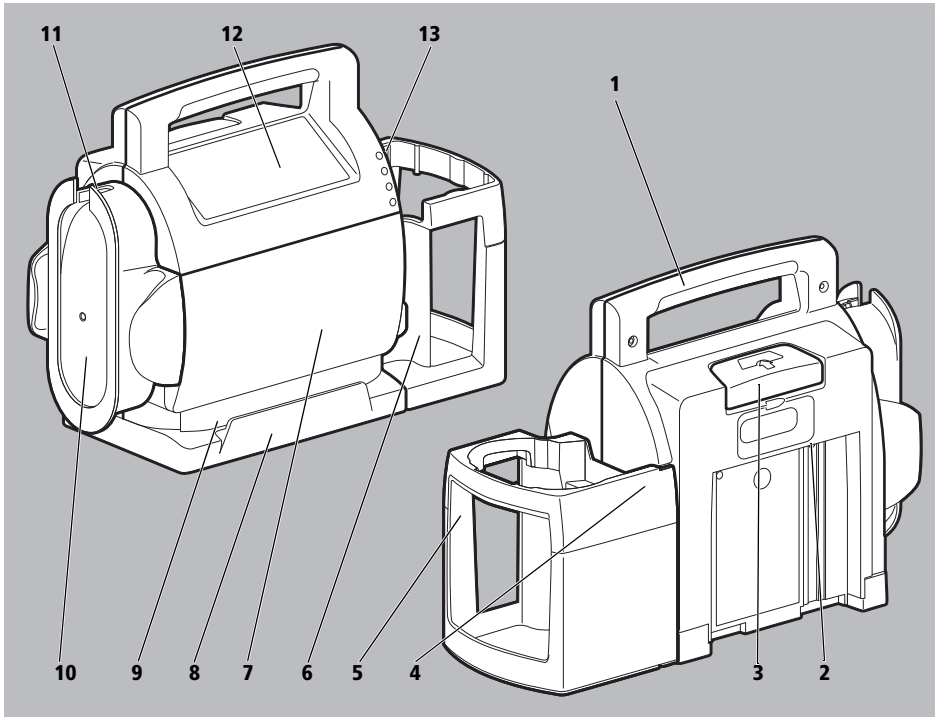

3-1 Device

No.	Designation	Description
1	Handle	Enables the device to be carried
2	Charging interface (covered)	Allows charging via a: <ul style="list-style-type: none"> • 12 V connection cable • Power supply unit and charger
3	Release catch	Disconnects the device from the wall mounting
4	Device inlet (covered)	Connects the device to the canister system
5	Holder for disposable canister system	Holds the disposable canister system and keeps it in position

No.	Designation	Description
6	Holder for reusable canister system	Holds the reusable canister system and keeps it in position
7	Battery compartment with cover and battery	<ul style="list-style-type: none"> • Houses the battery • Includes an interface for service purposes
8	Device base	<ul style="list-style-type: none"> • Protects the device against impacts • Prevents slippage • Guides the suction hose
9	Hose guide	Guides the suction hose
10	Suction hose reel	Used to store the suction hose if not required
11	Hose holder	Used to insert the suction hose
12	Control panel	Used to set and operate the device
13	Lock (covered)	Connects the holder for reusable canister system with the device inlet

3.2 Control panel

3.2.1 ACCUVAC Pro

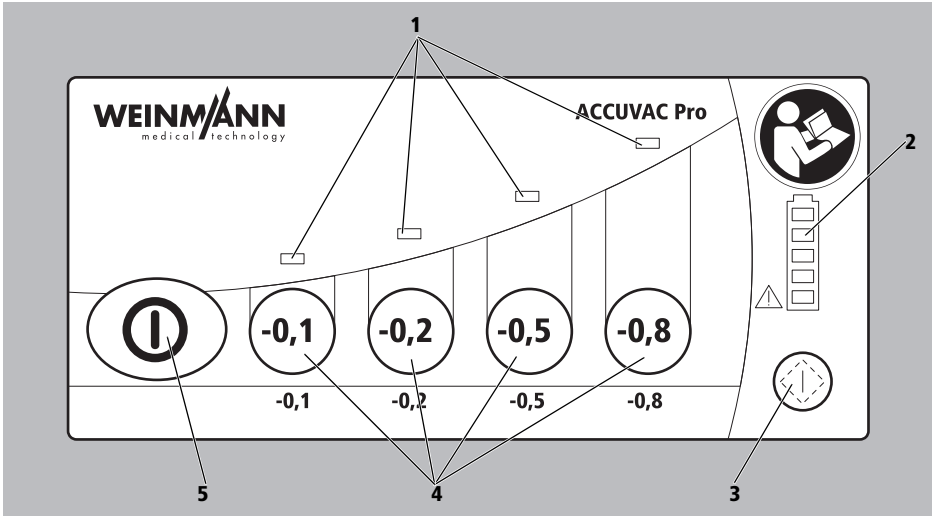

3-2 ACCUVAC Pro controls

No.	Designation	Description
1	Vacuum display	Displays the following vacuum: <ul style="list-style-type: none"> • Currently set vacuum (vacuum display flashes) • Attained vacuum (vacuum display stays illuminated)
2	Battery status indicator	Shows the battery status
3	Test button	<ul style="list-style-type: none"> • Starts the automatic function check • Activates the battery status indicator when the device is off
4	Vacuum button	Allows you to select the required vacuum
5	On/Off button	Switches the device on or off

3.2.2 ACCUVAC Lite

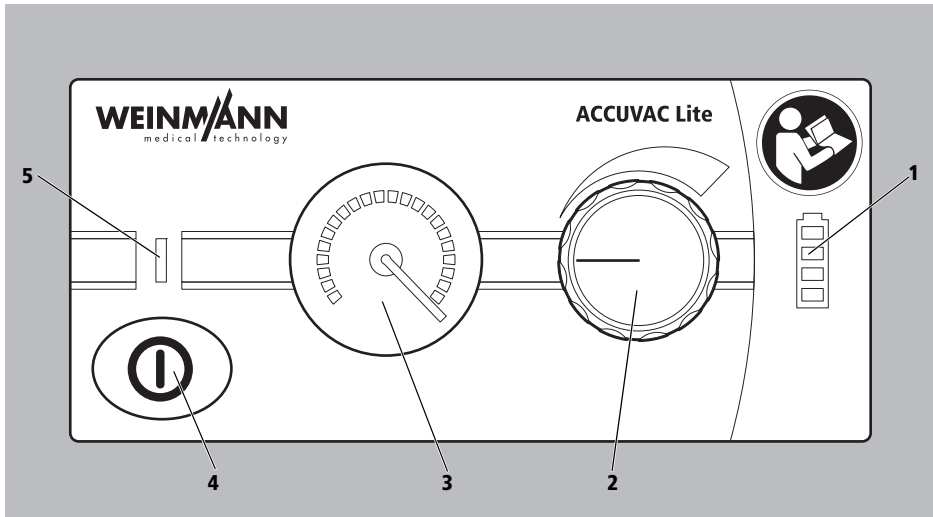

3-3 ACCUVAC Lite controls

No.	Designation	Description
1	Battery status indicator	Shows the battery status
2	Vacuum regulator	Allows you to select the required vacuum
3	Vacuum display	Displays the currently set vacuum
4	On/Off button	Switches the device on or off
5	Operation indicator	Displays whether the device is switched on/off

3.3 Accessories

3.3.1 Reusable canister system

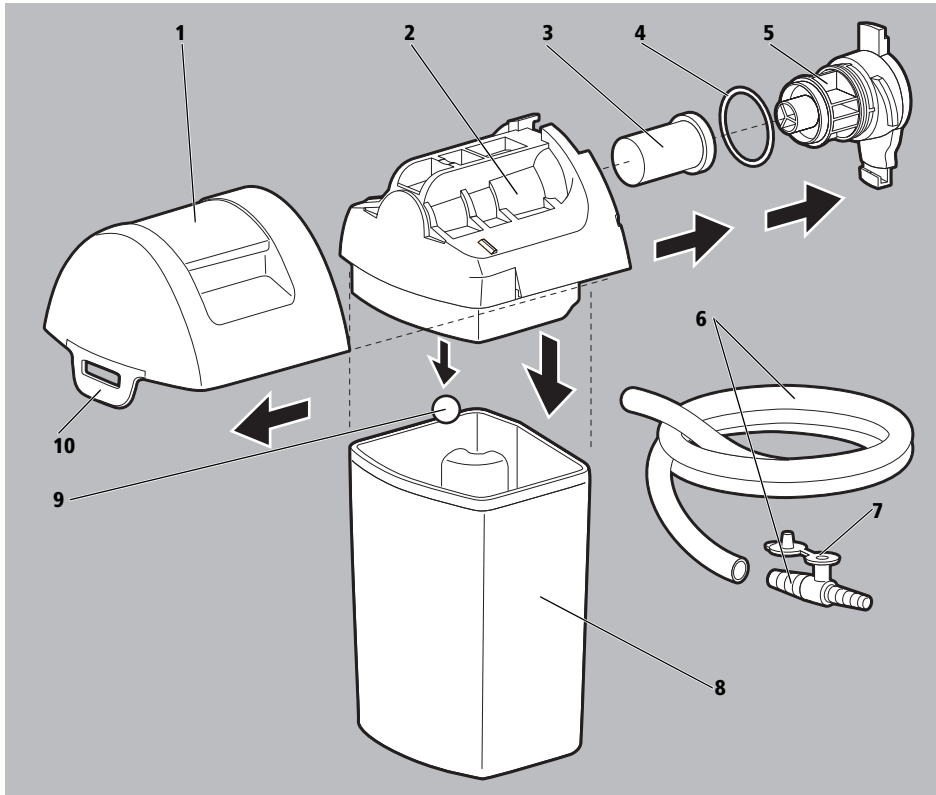

3-4 Reusable canister system

No.	Designation	Description
1	Upper section of secretions canister cover	Seals the reusable secretions canister
2	Lower section of secretions canister cover	Houses the filter holder with the bacteria filter and the float ball
3	Bacteria filter	Filters bacteria out of the suction material and protects against contamination
4	O-ring	Seals the connection between the filter holder and the lower section of the secretions canister cover

No.	Designation	Description
5	Filter holder	<ul style="list-style-type: none"> • Holds the bacteria filter in position • Locks the connection between the secretions canister cover and reusable secretions canister
6	Reusable suction hose with fingertip control	Suctions the suction material into the reusable secretions canister
7	Secondary air inlet	Used for manual regulation of the vacuum using a finger
8	Reusable secretions canister	Used to collect the suction material
9	Float ball	Serves as protection against overflowing
10	Canister latch	Holds the reusable canister system in the holder for reusable canister system

3.3.2 Disposable canister system

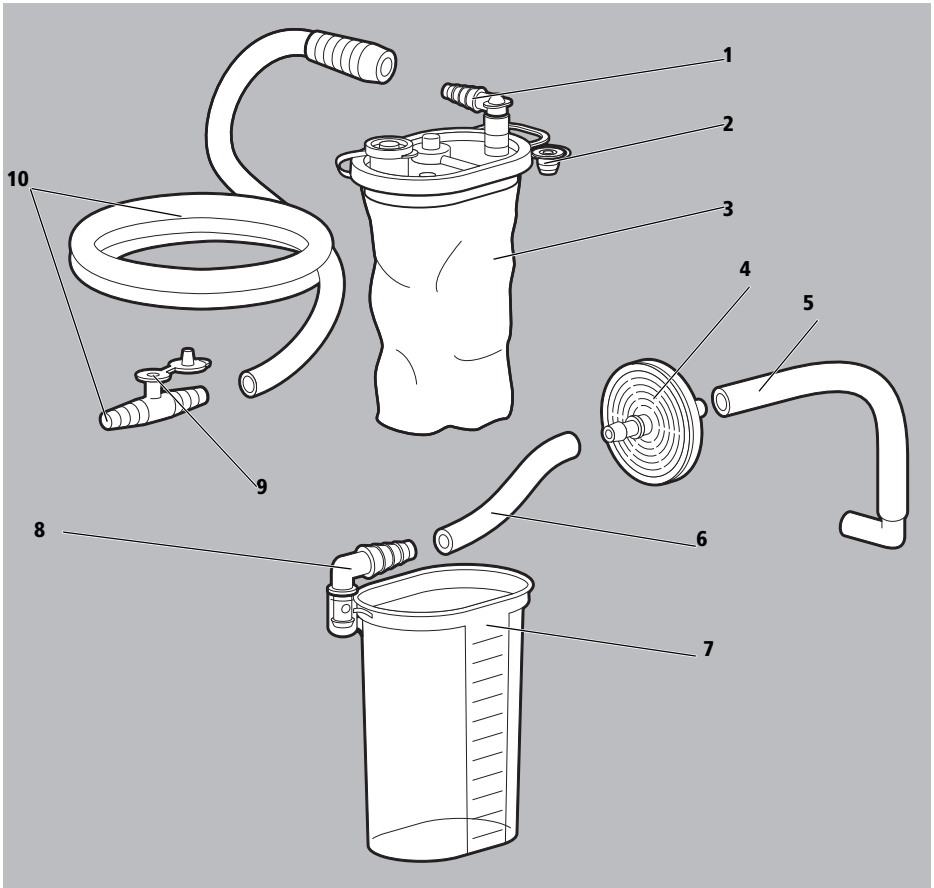

3-5 Disposable canister system

No.	Designation	Description
1	Elbow on Serres suction bag	Connects the Serres suction bag to the disposable suction hose
2	Cap on Serres suction bag	Seals the Serres suction bag after use
3	Serres suction bag	Used to collect the suction material
4	Hygiene filter	Used to filter the suction air
5	Vacuum tube	Connects the device inlet with the Serres secretions canister or with the hygiene filter

No.	Designation	Description
6	Connection hose for hygiene filter	Connects the hygiene filter with the Serres secretions canister
7	Serres secretions canister	Holds the Serres suction bag
8	Angled connector for Serres secretions canister	Connects the Serres secretions canister to the vacuum tube
9	Secondary air inlet	Used for manual regulation of the vacuum using a finger
10	Disposable suction hose with fingertip control	Conducts the suction material into the Serres suction bag

3.4 Other parts

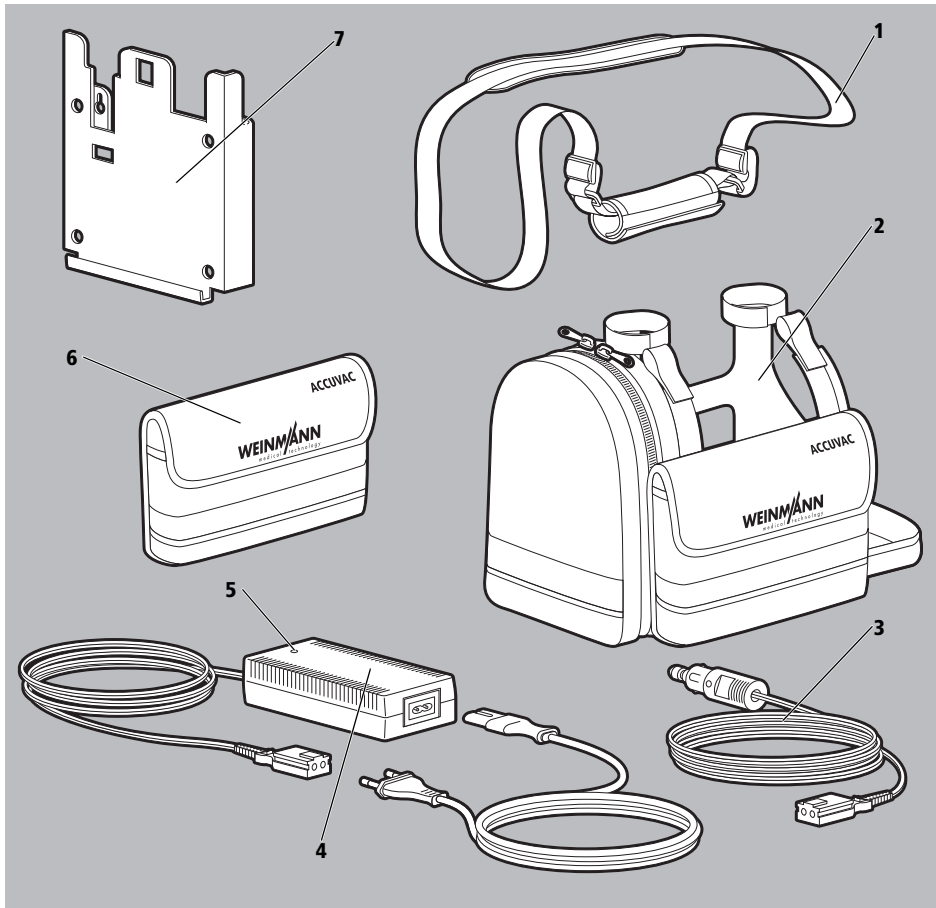











3-6 Accessories















No.	Designation	Description
1	Shoulder strap	Allows you to carry the device over your shoulder
2	Protective bag	<ul style="list-style-type: none"> Protects the device from damage Allows you to carry accessories
3	12 V connection cable	Connects the device's charging interface with a 12 V DC power source





No.	Designation	Description
4	Power supply unit and charger	Connects the device's charging interface with the line power
5	Pilot lamp (power supply unit and charger)	Displays whether the power supply unit and charger is connected to the line power
6	Accessories bag	Holds additional accessories and can be used with the shoulder strap
7	Wall mounting	Holds the device in place on a wall

3.5 Labels

Symbol	Description
	Article number
	Serial number
	European Article Number
	Manufacturer
	Date of manufacture
Type	Name of device
	Batch code
	CE mark (confirms that the product complies with the applicable European directives)
	
	UKCA mark (confirms that the device complies with the regulations of the United Kingdom)
	EAC mark (confirms that the product complies with the applicable safety requirements specified in the Technical Regulations of the Eurasian Economic Union (Eurasian Conformity))

Symbol	Description
Unique Device Identifier– UDI: Enables unambiguous identification of specific medical devices on the market	
Medical device	
Dealer	
Compatible devices	
Consult instructions for use.	
Refer to instructions for use.	
Attention: Observe the warning notices and precautions in the instructions for use	
China RoHS label (confirms that the product does not emit toxic substances for the number of years indicated)	
Disposable, do not reuse	
Short-term operation	
For indoor use only	
Storage temperature range limits	
Storage humidity range limits	
Air pressure range limits	
Maximum weight	
Do not iron	

Symbol	Description
	Wash at 30 °C
	Do not tumble dry.
	Store in a dry place.
	Protect the device against heat.
	Fragile
	Do not dispose of battery in household waste
	Do not dispose of device in household waste
 Pb	Contains lead, do not dispose of in household waste
 Pb	Contains lead, recycle
	European Recycling Platform
	Type BF applied part
	Direct current
	AC voltage
	Type of protection against electric shock: Protection class II device

Symbol	Description
IP34D	Degree of protection against:
IP40	<ul style="list-style-type: none"> • Ingress of solid objects • Ingress of dust • Ingress of water with harmful effect
	Input (100 V-240 V/50 Hz-60 Hz/1.1 A)
	Output (13.8 V/3.5 A)
PATIENT	Patient connection
IN	Indicates the side of the hygiene filter that has to face the angled connector for Serres secretions canister
	Indicates the correct installation direction of the battery
	Do not throw the battery into fire.
	Connect the battery Notice: The label is located beneath the battery cover.

4 Preparation and operation

4.1 Assembling the device

The device is delivered ready for use. Charge the battery fully before you use the device for the first time (see „4.3.2 Charging the battery“, page 34).

4.2 Connecting to a power supply

The device has the following power supply accessories:

- 12 V connection cable
- Power supply unit and charger

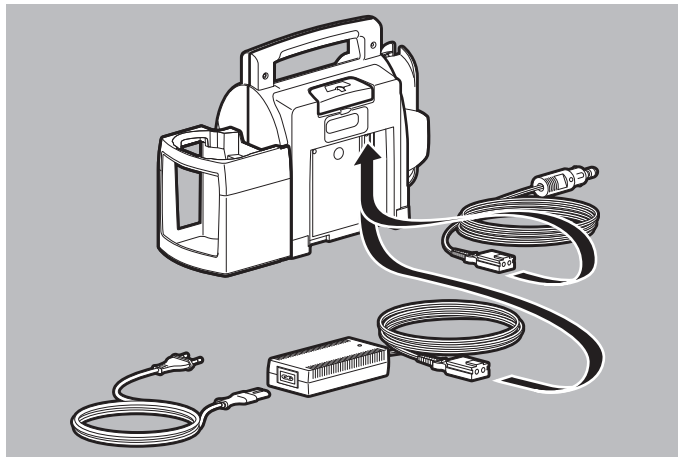

1. Connect the charging interface on the device to a 12 V DC power source via the 12 V connection cable

or

Connect the charging interface of the device to the line power via the power supply unit and charger.

Result The device is ready for use.

4.3 Using the rechargeable battery

4.3.1 General instructions

- Charge the battery fully before you use the device for the first time.
- Charge the battery under the prescribed ambient conditions (see „11.1 Technical data“, page 104). Charging outside of the prescribed ambient conditions interrupts the charging process. If necessary, restore the prescribed ambient conditions. Avoid exposure to direct sunlight and proximity to heaters.
- You can also operate the device while it is charging.
- If the battery is not in the device or is completely discharged or defective, you can operate the device with the power supply accessories.
- Replace the battery if its runtime becomes noticeably reduced.
- The service life of the ACCUVAC Pro battery is exhausted after approx. 500 charging cycles in approx. 4 years. The battery of the ACCUVAC Lite is designed for 400 charging cycles in approx. 3 years.
- Observe the storage instructions for the battery (see „9 Storage“, page 101).
- Storing the battery for too long without charging can deeply discharge the battery. A deeply discharged battery is defective and must be replaced. Always store the device with the battery charged.
- If all the LEDs on the battery status indicator flash when the power supply accessories are connected, ensure that the battery is connected and you are using an original spare part (ACCUVAC Pro).

4.3.2 Charging the battery

NOTICE

Material damage if the battery is deeply discharged!

A deeply discharged battery no longer performs optimally and must be replaced.

⇒ Charge the battery at the latest when an audible signal sounds or the red status LED of the battery status indicator flashes quickly (ACCUVAC Pro).

⇒ Charge the battery at the latest when the red status LED of the battery status indicator lights up (ACCUVAC Lite).

1. Place the device in the wall mounting with the power supply connected (see „4.5.2 Placing the device in the wall mounting“, page 56)

or

Connect the charging interface on the device to a 12 V DC power source via the 12 V connection cable

or

Connect the charging interface of the device to the line power via the power supply unit and charger.

The charging process begins:

ACCUVAC Pro

- All the green status LEDs up to the status LED for the current battery status light up at the same time.
- The status LED for the current battery status lights up permanently and the green status LEDs flash successively.
- The top green status LED lights up permanently once the charging process is complete.

ACCUVAC Lite

The top green status LED lights up.



Recommendation: Charge the ACCUVAC Lite if the lower green status LED of the battery status indicator lights up. In this way you ensure that there is sufficient operating time available for the next use.

Result The battery is charged.



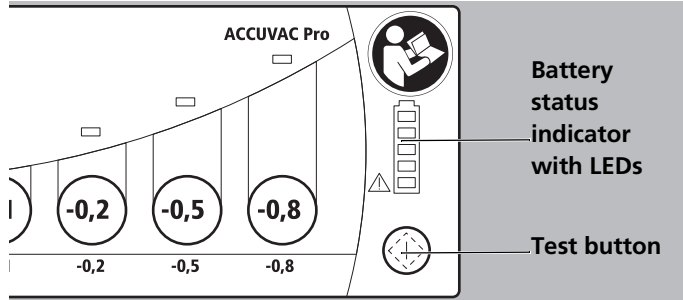

4.3.3 Battery status indicator

ACCUVAC Pro

You can read the battery status off the battery status indicator on the control panel. When the device is on, the battery status is indicated by 4 green status LEDs and 1 red status LED. When the device is off, the battery status indicator is activated by pressing the test button.



4-1 ACCUVAC Pro battery status indicator

Battery status indicator	Explanation	Meaning
	4 green status LEDs light up	Battery status < 100 %
	3 green status LEDs light up	Battery status < 85 %
	2 green status LEDs light up	Battery status < 60 %
	1 green status LED lights up	Battery status < 35 %

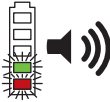

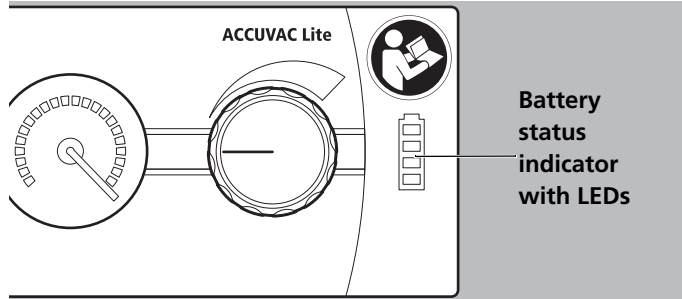

Battery status indicator	Explanation	Meaning
	1 green status LED flashes	Battery status < 15 %
	1 green status LED and the red status LED flash quickly and an audible signal sounds	Battery status < 10 %
	After pressing the test button: The green status LEDs flash quickly several times.	Battery status query runs when the device has been switched off for longer than 10 mins

ACCUVAC Lite

You can read the battery status off the battery status indicator on the control panel. The battery status is indicated by 3 green status LEDs and 1 red status LED.



4-2 ACCUVAC Lite battery status indicator

Battery status indicator	Explanation	Meaning
	Only the top green status LED lights up	Battery status \leq 100 %
	Only the middle green status LED lights up	Battery status approx. 60 %
	Only the lower green status LED lights up	Battery status approx. 40 %
	Only the red status LED lights up	<ul style="list-style-type: none"> Battery status < 10 % Charge battery
	The red status LED lights up after the battery has been charged for an extended period of time	<ul style="list-style-type: none"> The battery has reached the end of its service life or Battery defective

4.3.4 Preparing for a battery replacement

Requirement

- The device is switched off (see „4.7 Switching off the device“, page 62).
- The device is disconnected from the power supply.

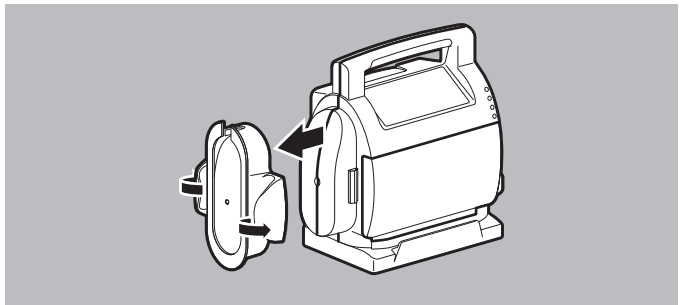

- Press the two wings of the suction hose reel apart with your thumbs and pull the reel off the device.

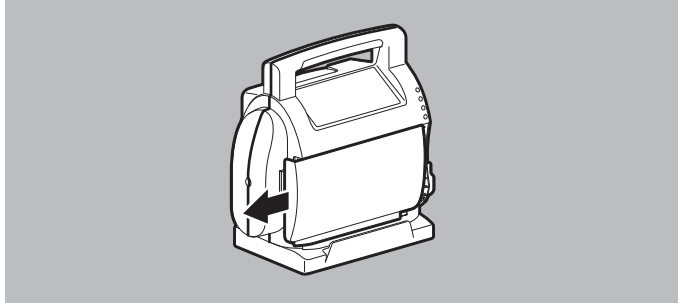

2. Push the battery compartment cover to the left.

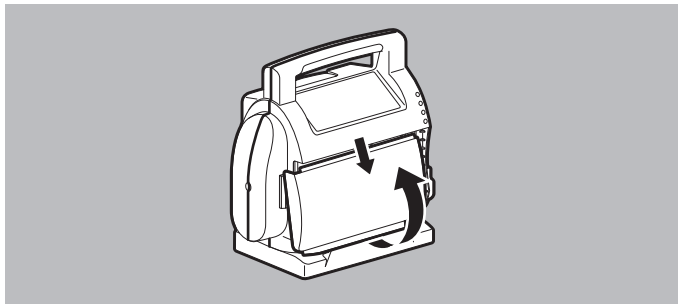

3. Lift up the bottom of the battery compartment cover and pull it out of the top guide.

4. Lay the device down on the lower part of the housing. The opened battery compartment faces upward.

Result Preparations for battery replacement are complete.

4.3.5 Changing the battery (ACCUVAC Pro)

Requirement Preparations for the battery replacement are complete (see „4.3.4 Preparing for a battery replacement“, page 37).

NOTICE

Material damage if the release catch on the battery connector is not pressed!

Pulling the battery out without pressing the **release catch on the base** of the battery connector can damage the electronics of the device.

⇒ Always release the battery connector using the release catch before pulling the battery out.

NOTICE**Damage to device due to faulty or incorrect connection of the battery connector!**

If battery connector is faulty or incorrectly connected, the device cannot be used with battery operation. The device cannot be charged or switched on or off.

- ⇒ Check the connection of the battery connector in the battery compartment.
- ⇒ Disconnect the wrongly fitted battery connector.
- ⇒ Connect the battery connector to the device as shown in the picture.

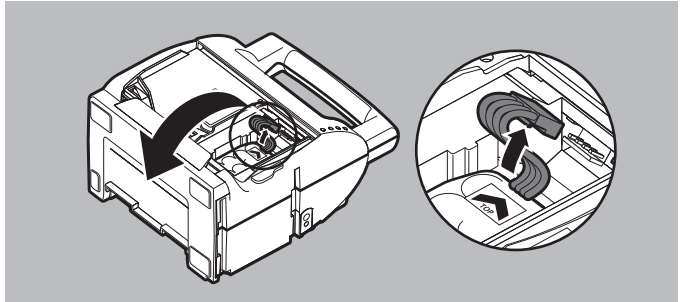

1. Press the release catch on the base of the battery connector.
2. Pull the battery connector out of the socket in the battery compartment.

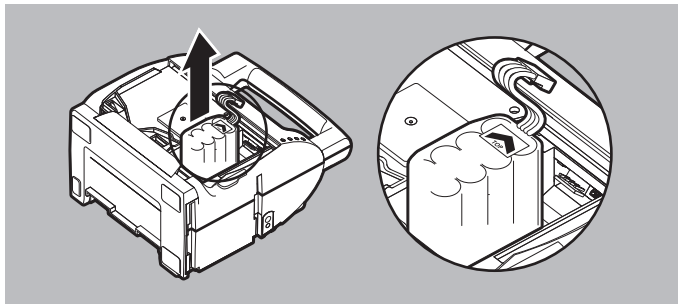

3. Pull the battery out of the device.
4. Insert a new battery.
When doing so, note: The symbol  must point toward the socket in the battery compartment.

5. Push the battery connector into the socket in the battery compartment until it clicks into place.
When doing so, note: All pins must be connected with the plug.
6. Install the battery compartment cover (see „4.4.2 Installing the battery compartment cover“, page 44).
7. Install the suction hose reel (see „4.4.3 Installing the suction hose reel“, page 45).
8. To check whether the battery is correctly inserted: Switch on the device (see „4.6 Switching on the device“, page 61).
9. Switch off the device (see „4.7 Switching off the device“, page 62).
10. Charge battery (see „4.3.2 Charging the battery“, page 34).
11. Perform a function check (see „6.2 Performing a function check“, page 89).

Result The battery is changed.

4.3.6 Changing the battery (ACCUVAC Lite)

Requirement Preparations for the battery replacement are complete (see „4.3.4 Preparing for a battery replacement“, page 37).

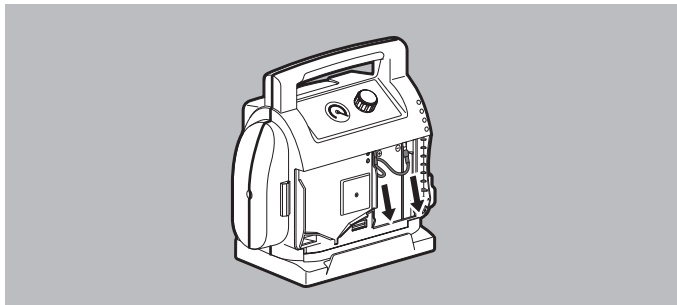

1. Detach the red and black cables from the contacts on the battery.
2. Stand the device up.

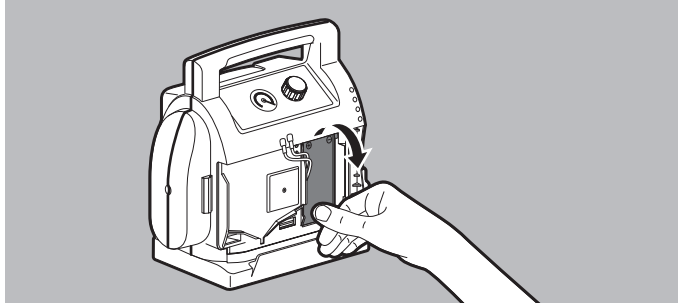

3. Press against the lower end of the battery.
The battery must tilt forwards.
4. Tilt the battery out of the battery compartment and remove it.

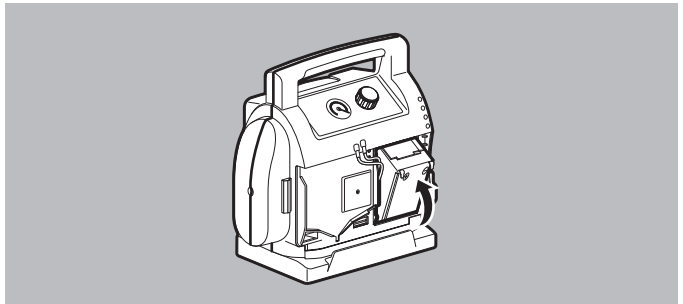

5. Insert a new battery in the lower guide of the battery compartment.
The battery must be tilted in the battery compartment.
6. Lay the device down on the lower part of the housing.
The opened battery compartment faces upward.
7. Press the battery into the lower guide of the battery compartment until it sits horizontally in the battery compartment.
8. Connect the red cable to the plus contact on the left of the battery.
9. Connect the black cable to the minus contact on the right of the battery.
10. Install the battery compartment cover (see [„4.4.2 Installing the battery compartment cover“](#), page 44).

11. Install the suction hose reel (see „4.4.3 Installing the suction hose reel“, page 45).
12. To check whether the battery is correctly inserted: Switch on the device (see „4.6 Switching on the device“, page 61).
13. Switch off the device (see „4.7 Switching off the device“, page 62).
14. Charge battery (see „4.3.2 Charging the battery“, page 34).
15. Perform a function check (see „6.2 Performing a function check“, page 89).

Result The battery is changed.

4.4 Connecting parts

4.4.1 Installing the device base

- Requirement*
- The canister system is removed.
 - The holder for canister system is removed.
 - The suction hose reel is removed.
 - The battery compartment cover is removed.

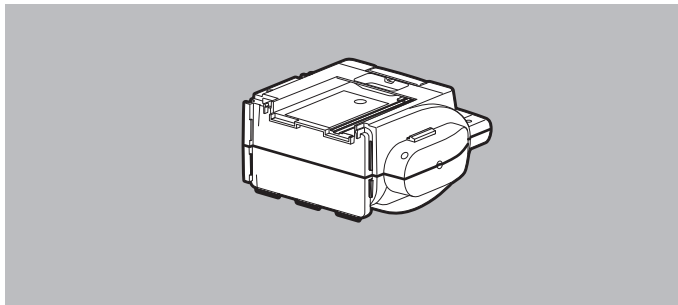

1. Lay the device on the upper part of housing.

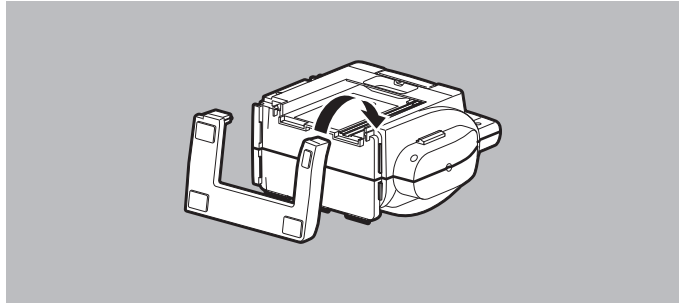

2. Hook the device base into the top corner on the suction hose reel side.

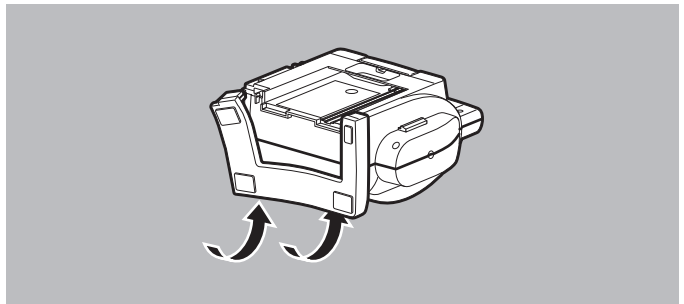

3. Press the device base into the guide along the suction hose reel side and along the bottom.

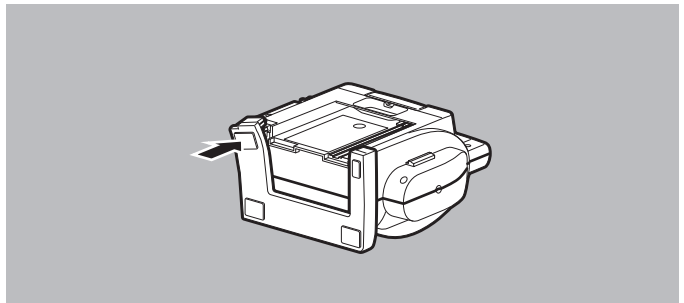

4. Hook the device base into the top corner on the canister system side.

Result The device base is installed.

4.4.2 Installing the battery compartment cover

Requirement The device base is installed (see „4.4.1 Installing the device base“, page 42).

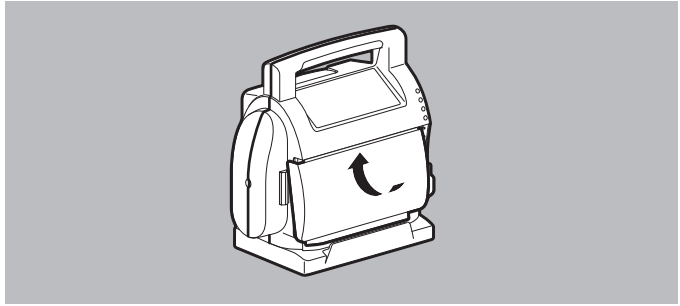

1. Insert the battery compartment cover in the upper guide of the battery compartment.

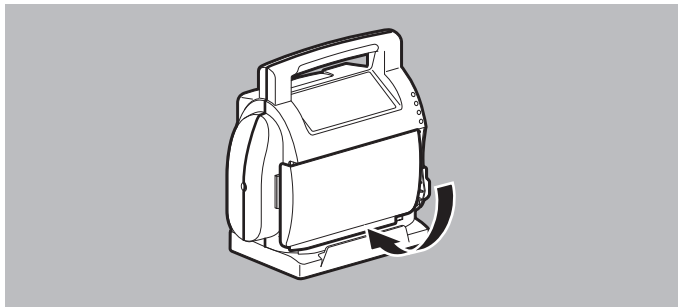

2. Fold down the battery compartment cover into the lower guide of the battery compartment.

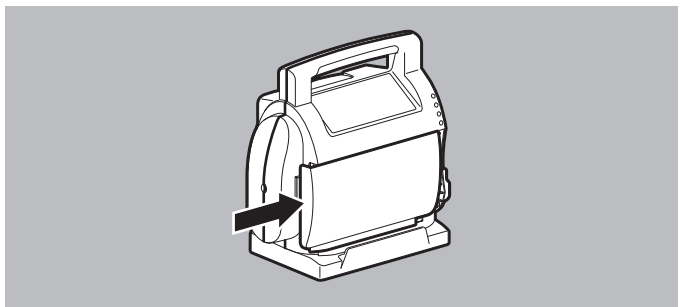

3. Push the battery compartment cover to the right until it audibly clicks into place.

Result The battery compartment cover is installed.

4.4.3 Installing the suction hose reel

- Requirement*
- The device base is installed (see „4.4.1 Installing the device base“, page 42).
 - The battery compartment cover is installed (see „4.4.2 Installing the battery compartment cover“, page 44).

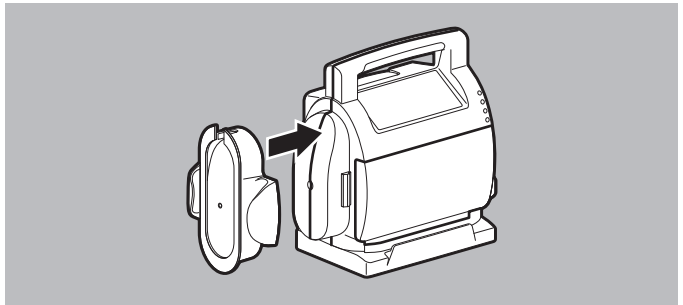

1. Push the suction hose reel, with the hose holder at the top, onto the side of the device until it audibly clicks into place.

Result The suction hose reel is installed.

4.4.4 Installing the holder for canister system

The holder is installed in the same way for both devices. There are two types of holders:

- Holder for reusable canister system
- Holder for disposable canister system

Requirement The device base is installed (see „4.4.1 Installing the device base“, page 42).

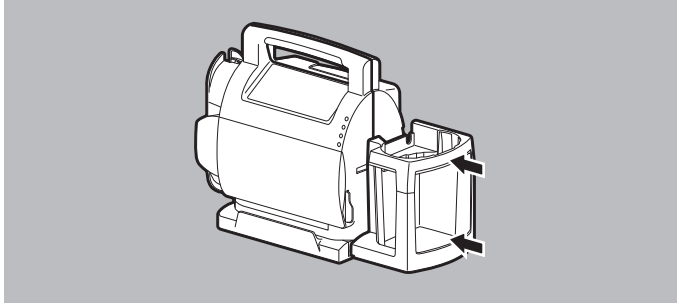

1. Insert the holder **centrally** in the guides on the right side of the device.
When doing so, note: The holder must be inserted in both guides.

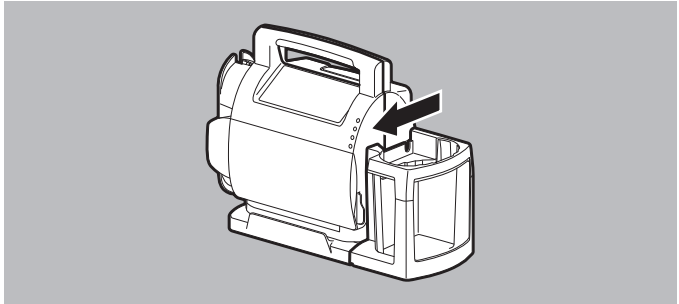

2. Push the holder to the end of the guides.
When doing so, note:
 - The holder must be flush with the device base and the lower part of the housing.
 - The device inlet must be freely accessible.

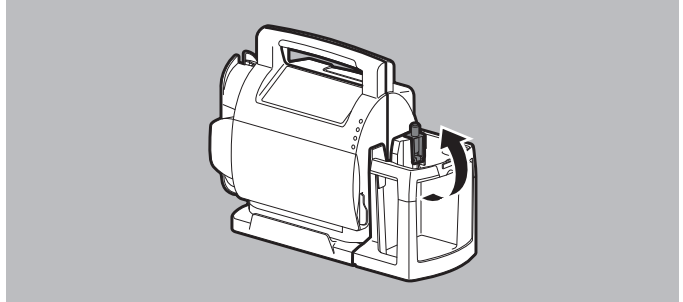

3. Holder for reusable canister system: Push the lock through the recess on the holder in the device inlet.

Result The holder for reusable canister system/holder for disposable canister system is installed.

4.4.5 Connecting the reusable canister system

WARNING

Risk of infection due to contaminated bacteria filter and secretions canister cover!

Contaminated bacteria filters and secretions canister covers can infect the patient and user.

- ⇒ Always operate the device with a bacteria filter.
- ⇒ Keep a replacement bacteria filter at the ready.
- ⇒ Always wear suitable gloves.
- ⇒ Only use new, dry bacteria filters.
- ⇒ Replace the bacteria filter after every patient.
- ⇒ Replace the bacteria filter after a maximum of two weeks if no patient change has occurred.

Requirement The holder for reusable canister system is installed (see „4.4.4 Installing the holder for canister system“, page 45).

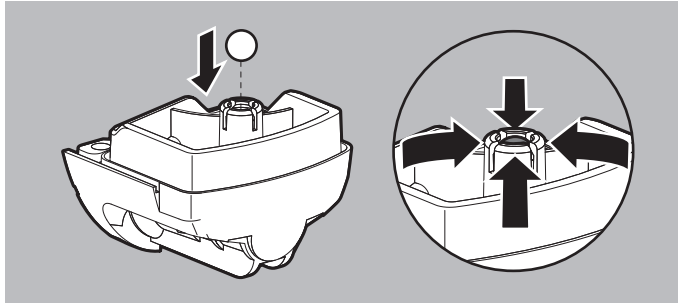

1. Press the segments of the ball holder apart gently and insert the float ball into the ball holder in the lower section of the secretions canister cover.
2. Press the segments of the ball holder together gently. When doing so, note:
 - The float ball must not fall out of the ball holder.
 - The float ball must be able to move freely.

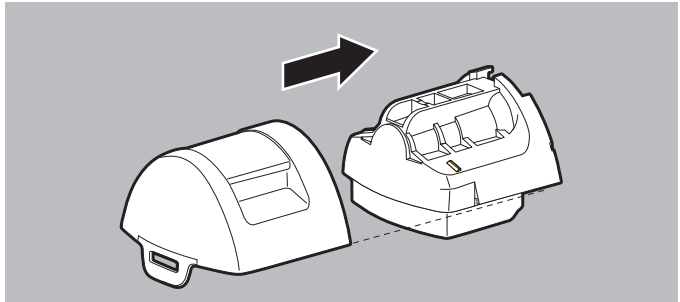

3. Push the upper section of the secretions canister cover onto the lower section of the secretions canister cover.
4. Place the reusable secretions canister on a stable surface.

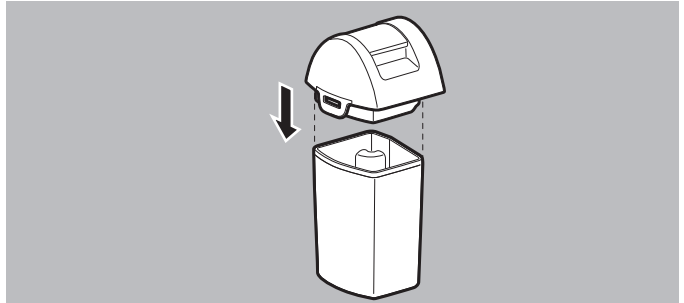

5. Place the secretions canister cover on the reusable secretions canister.
6. Press the cover onto the canister with both hands.

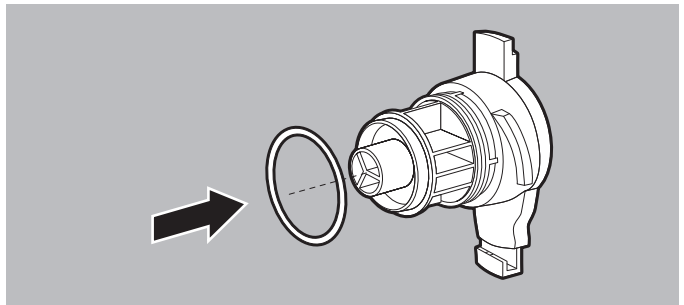

7. If necessary: Push the O-ring onto the filter holder.

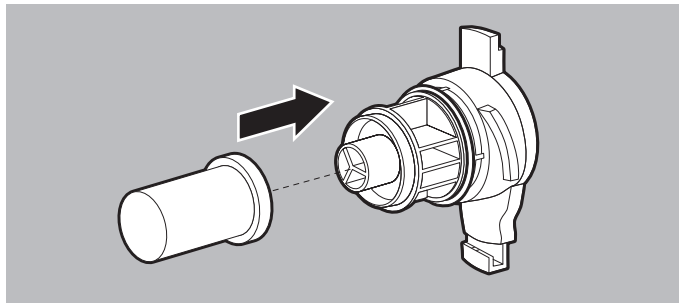

8. Place the new bacteria filter on the filter holder.

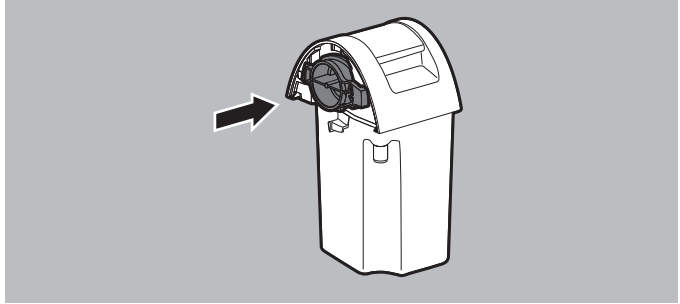

9. Insert the filter holder into the lower section of the secretions canister cover.
When doing so, note: The filter holder must be in a horizontal position.

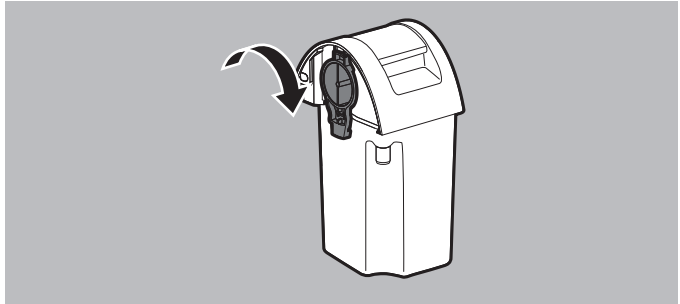

10. Turn the filter holder as far as it will go clockwise.
When doing so, note: The filter holder must be in a vertical position and click into place in the detent lug on the reusable secretions canister.

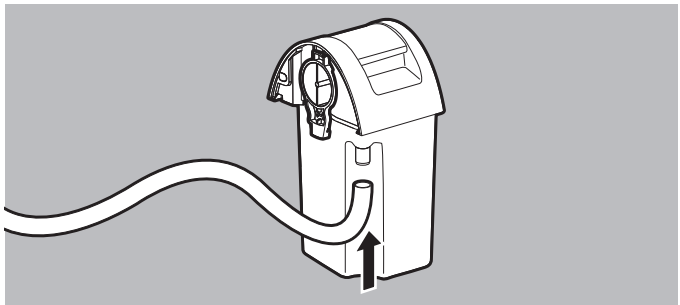

11. Connect the reusable suction hose to the reusable secretions canister.

12. Connect the fingertip control to the reusable suction hose.

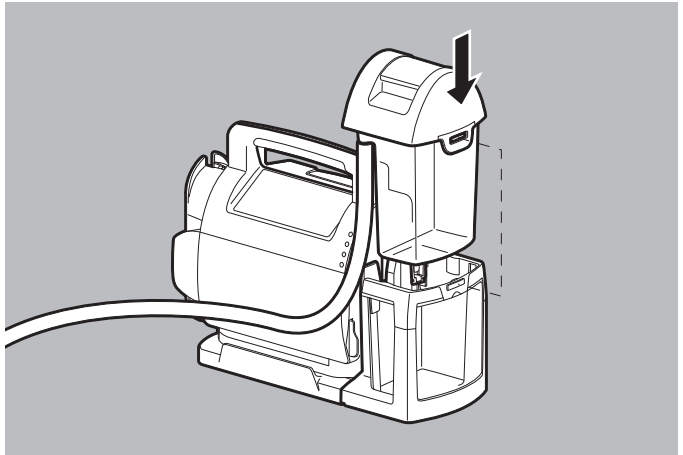

13. Insert the reusable canister system into the holder for reusable canister system from above.
The canister latch must engage fully in the holder.

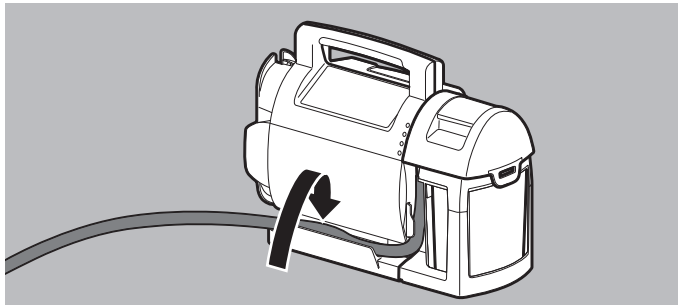

14. If necessary: Place the reusable suction hose in the hose guide on the device base.

15. If necessary: Coil the reusable suction hose on the suction hose reel.

16. If necessary: Clamp the reusable suction hose in the hose holder.

17. Perform a function check (see „6.2 Performing a function check“, page 89).

Result The reusable canister system is installed in the holder for reusable canister system.

4.4.6 Connecting the disposable canister system

⚠ WARNING

Risk of injury if the manufacturer's specifications are not followed!

Failure to comply with the manufacturer's specifications may cause injury to the patient and damage the device, accessories and other parts.

⇒ Observe the instructions for use from the manufacturer, Serres.

⚠ WARNING

Risk of infection due to contaminated hoses, tubes and Serres secretions canisters!

Contaminated hoses, tubes and Serres secretions canisters can infect the patient and user.

⇒ Only use Serres suction bags with an integrated bacteria filter.

⇒ Only use sterile packed parts if the packaging is undamaged.

Requirement The holder for disposable canister system is installed (see „4.4.4 Installing the holder for canister system“, page 45).

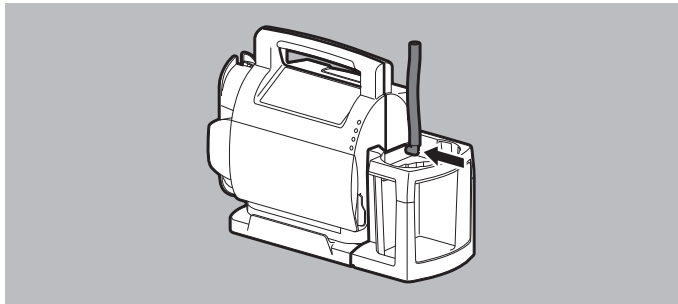

1. Connect the vacuum tube on the right side of the device to the device inlet.

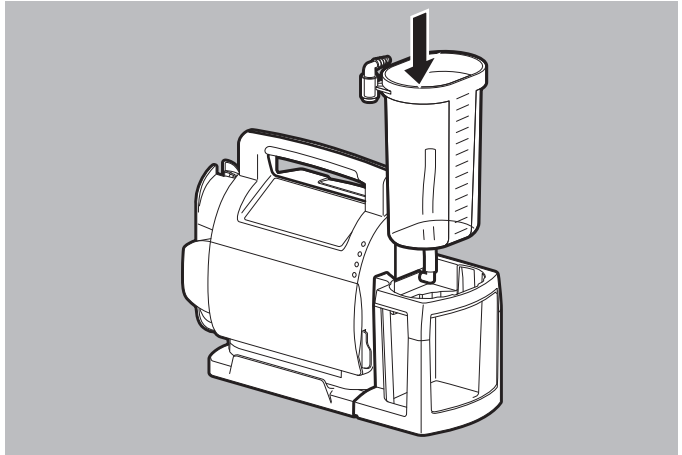

2. Insert the Serres secretions canister into the holder for disposable canister system from above.

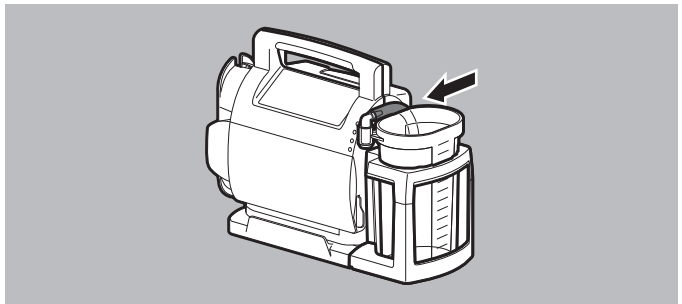

3. Connect the vacuum tube to the angled connector for Serres secretions canister.
4. Unfold the Serres suction bag.

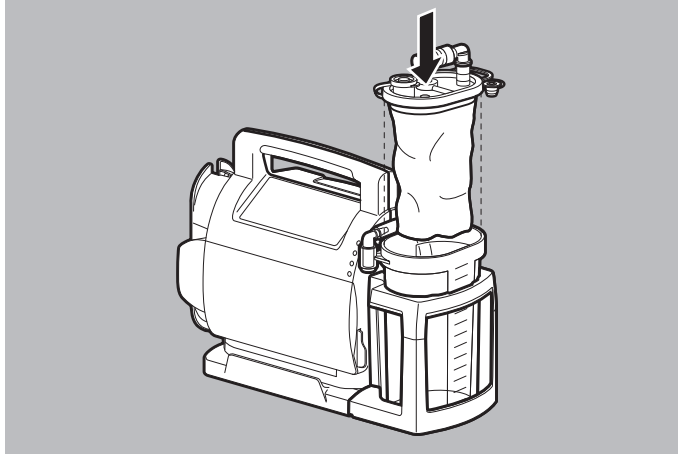

5. Insert the Serres suction bag in the Serres secretions canister. When doing so, note:
 - Only use intact Serres suction bags to protect the device from contamination.
 - The film of the Serres suction bag must be completely inside the Serres secretions canister and the lid of the Serres suction bag must close off the Serres secretions canister tightly.
6. Switch on the device (see [„4.6 Switching on the device“, page 61](#)).
7. Select a vacuum of -0.8 bar and press on the center of the Serres suction bag from above. The suction bag must unfurl.
8. Close the elbow connector on the Serres suction bag with your finger. The Serres suction bag must unfurl completely until it rests on the base and against the sides of the Serres secretions canister.
9. Connect the disposable suction hose to the elbow connector on the Serres suction bag.
10. If necessary: Switch off the device (see [„4.7 Switching off the device“, page 62](#)).

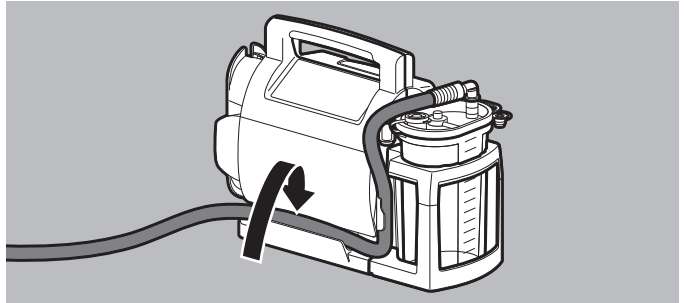

11. If necessary: Place the disposable suction hose in the hose guide on the device base.
12. If necessary: Coil the disposable suction hose on the suction hose reel.
13. Perform a function check (see „6.2 Performing a function check“, page 89).

Result The disposable canister system is installed in the holder for disposable canister system.

4.5 Connecting accessories and other parts

4.5.1 Connecting the hygiene filter for disposable canister system

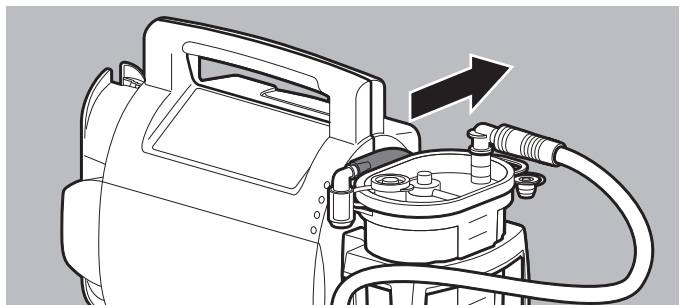

1. Remove the vacuum tube from the angled connector for Serres secretions canister.

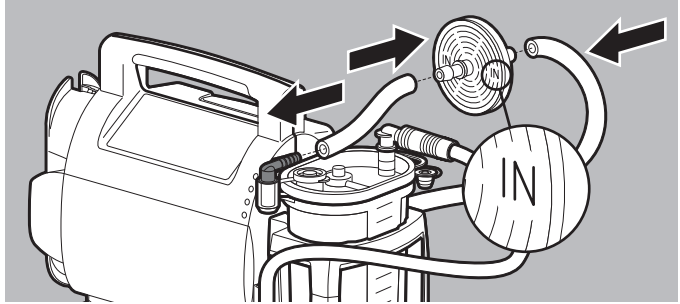

2. Connect the vacuum tube and the connection hose for the hygiene filter to the hygiene filter. When doing so, note:
 - The IN label on the hygiene filter must be facing the angled connector for Serres secretions canister.
 - The vacuum tube and connection hose for the hygiene filter must be pushed on as far as they will go.
3. Connect the connection hose for hygiene filter to the angled connector for Serres secretions canister.

4.5.2 Placing the device in the wall mounting

Requirement

- The wall mounting is installed as per the assembly instructions.
 - The 12 V connection cable or the power supply unit and charger is clicked into place in the guide rail of the wall mounting.
1. Connect the 12 V connection cable to a 12 V DC power source
or
 Connect the power supply unit and charger to the line power.

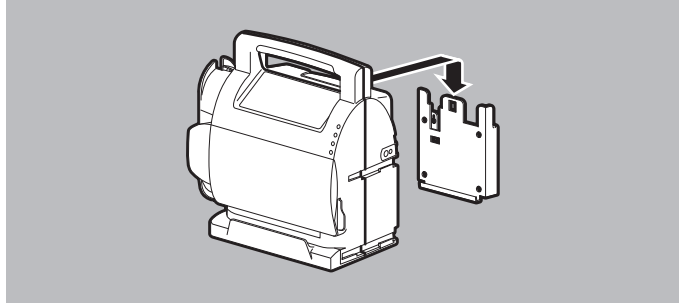

2. Place the device in the wall mounting.
3. Check that the device is securely positioned in the wall mounting.

Result The device is positioned in the wall mounting.

4.5.3 Taking the device out of the wall mounting

CAUTION

Risk of injury if the device should fall!

The device may fall if taken out of the wall mounting incorrectly. This can injure the user and patient and damage the device.
 ⇒ Hold the device firmly by the handle while removing.

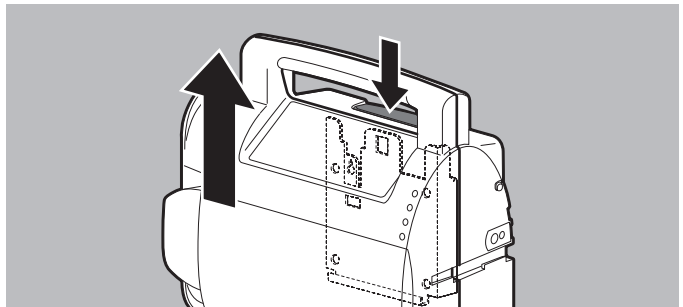

1. Press the release catch on the device.
2. Pull the device upwards out of the wall mounting.

Result The device is removed from the wall mounting.

4.5.4 Attaching the protective bag

Requirement

- The suction hose reel is installed (see „4.4.3 Installing the suction hose reel“, page 45).
- There is a canister system installed.

CAUTION

Risk of injury if the device is not held firmly in the wall mounting!

If the protective bag covers a recess intended for the wall mounting, the device may not click into place properly in the wall mounting and may fall out. This can injure the user and patient and damage the device.

- ⇒ Ensure the recess for the wall mounting is not covered.
- ⇒ Check that the device is securely positioned in the wall mounting.

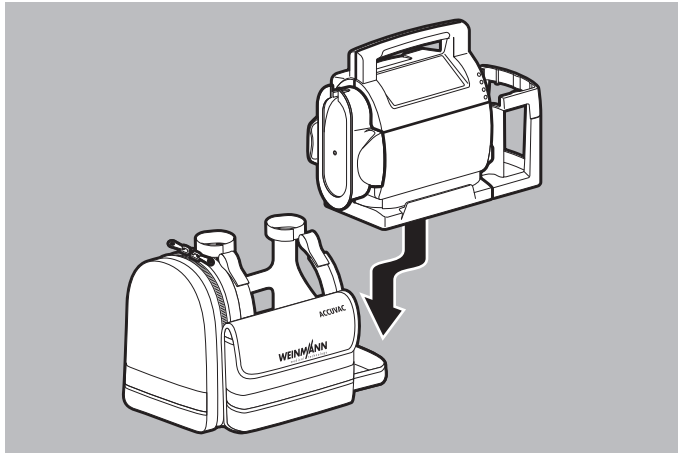

1. Insert the suction hose reel end of the device sideways into the protective bag from above.
2. Push the device as far as possible to the left into the protective bag.
3. Adjust the canister system on the bottom of the protective bag.

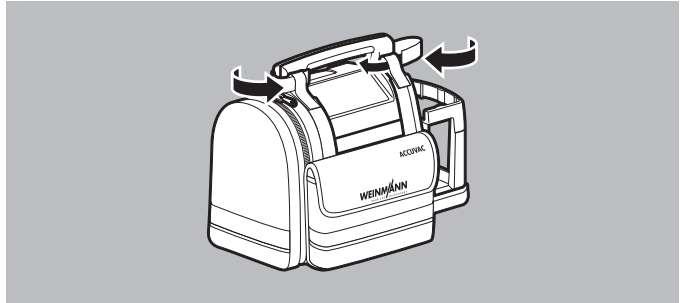

4. Pass the hook and loop fasteners of the protective bag through the loops on the protective bag.
5. Pass the hook and loop fasteners around both ends of the handle and close them.

Result The protective bag is attached.

4.5.5 Attaching the accessories bag

Requirement A battery compartment cover for accessories bag has been installed (see „4.4.2 Installing the battery compartment cover“, page 44).



1. Pass the hook and loop fasteners of the accessories bag through the eyelets on the battery compartment cover.
2. Affix the hook and loop fasteners on the bottom of the accessories bag.

Result The accessories bag is attached.

4.5.6 Attaching the shoulder strap

⚠ CAUTION

Risk of injury if the shoulder strap is not used correctly or not attached correctly!

The device may fall out if the shoulder strap is not used correctly or is not attached to the device correctly. This can injure the user and patient and damage the device.

- ⇒ Observe the maximum load of the shoulder strap.
- ⇒ Do not attach any other or heavier objects to the shoulder strap.
- ⇒ Wrap the hook and loop fastener of the shoulder strap around the device's handle tightly and close it.
- ⇒ Keep the hook and loop fastener of the shoulder strap free from foreign particles and replace it regularly.

NOTICE

Material damage if the shoulder strap is not correctly attached to the device!

The device may fall and become damaged if the shoulder strap is not attached to the device correctly.

- ⇒ Wrap the hook and loop fastener of the shoulder strap around the device's handle tightly and close it.
- ⇒ Keep the hook and loop fastener free from foreign particles and replace it regularly.
- ⇒ Observe the maximum load of the shoulder strap.

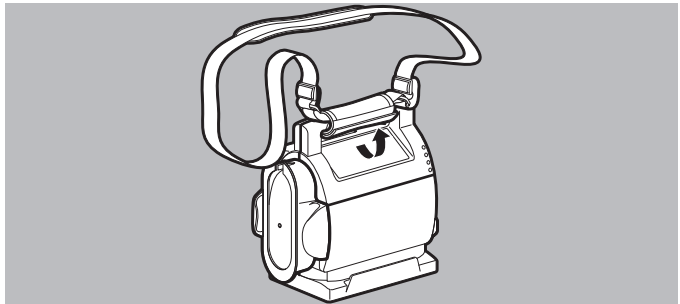

1. Wrap the hook and loop fastener of the shoulder strap around the device's handle tightly and close it.

Result The shoulder strap is attached.

4.6 Switching on the device

NOTICE

Material damage if the battery is not completely charged the first time the device is used!

Failure to charge the battery completely before the device is used for the first time can damage the battery.

⇒ Only operate the device with a battery showing at least 2 green status LEDs.

Requirement

- A battery showing at least 2 green status LEDs is in the device
 - or**
 - The device is connected to the power supply accessories.
1. Switch on the device using the On/Off button (ⓘ) :

ACCUVAC Pro

- All the LEDs on the control panel light up briefly.
- The battery status indicator displays the battery status.
- The device starts with the last set vacuum. The corresponding LED of the vacuum display flashes.
- The background illumination and the LEDs of the On/Off button (ⓘ) light up.

ACCUVAC Lite

- The battery status indicator displays the battery status.
- The operation indicator lights up.

Result The device is ready for use.

4.7 Switching off the device

1. Press and hold the On/Off button  for approx. 1 second.

ACCUVAC Pro

The LEDs of the On/Off button  stay lit up for another 10 minutes.

ACCUVAC Lite

The operation indicator goes out.

Result The device is completely switched off.

4.8 Performing suction

WARNING

Risk of asphyxia if the device fails or switches itself off during suction!

Devices which fail or switch themselves off impede suction and can result in serious injury to or death of the patient.

- ⇒ Keep an alternative means of suction available at all times.
- ⇒ Do not use the device in short-term operation for longer than 60 minutes (ACCUVAC Pro) or 45 minutes (ACCUVAC Lite).
- ⇒ Check the battery status repeatedly and charge the battery if necessary.

WARNING

Risk of injury due to lack of knowledge and failure to follow procedure!

The use of the device by users without medical qualifications and training in suction and/or the failure to follow procedure can result in serious injury to or death of the patient.

- ⇒ Only use the device if the user has a medical qualification or is familiar with suction and the operation of the device.
- ⇒ Only use the device if the user has been trained in the suction technique by a physician and is familiar with suction and the operation of the device.
- ⇒ Observe national and regional provisions and organizational procedure on suction.

WARNING**Risk of infection from reused disposables and contaminated or damaged parts!**

Reused disposables and contaminated or damaged parts can infect the patient or user.

- ⇒ Use new disposables for each patient.
- ⇒ Only use a hygienically reprocessed canister system.
- ⇒ Replace damaged parts before use.

WARNING**Risk of infection from suction material!**

Suction material can come into contact with the user and infect him/her.

- ⇒ Always wear suitable gloves.

Requirement

- The suction hose reel is installed (see „4.4.3 Installing the suction hose reel“, page 45).
 - A canister system with suction hose and fingertip control is installed.
1. Perform a function check (see „6.2 Performing a function check“, page 89).
 2. Switch on the device (see „4.6 Switching on the device“, page 61).
 3. Uncoil the suction hose with fingertip control from the suction hose reel.
 4. If necessary: Connect additional accessories such as a suction catheter.

WARNING**Risk of injury due to vacuum which is too high!**

Too high a vacuum can damage the patient's tissue.

- ⇒ Adapt the vacuum to suit the patient.
- ⇒ Observe the applicable guidelines.

5. Select the required vacuum:

ACCUVAC Pro

Press the vacuum button for the required vacuum.

- The vacuum display of the selected vacuum button flashes green.
- The vacuum display of the attained vacuum lights up green.

ACCUVAC Lite

Close off the open end of the fingertip control with a finger and set the required vacuum with the vacuum regulator. The vacuum display shows the selected vacuum.

WARNING**Risk of injury due to careless suction or unsuitable equipment!**

Careless suction or unsuitable equipment can cause injuries in the patient's airways.

⇒ Open the secondary air inlet briefly if the suction catheter becomes attached to the skin.

⇒ Suction with particular care in the tracheal area.

6. Close the secondary air inlet on the fingertip control with your finger.
The device suctions.
7. If necessary: Open the secondary air inlet on the fingertip control.
The device does not suction.



If you interrupt the suction briefly, you can clamp the suction hose in the hose holder on the suction hose reel.



Do not kink the hoses/tubes as this will reduce the suction capacity.

8. If the reusable secretions canister of the reusable canister system is half full: Empty the reusable secretions canister (see „4.9.1 Emptying the reusable secretions canister“, page 65).



If the reusable secretions canister is too full, the float ball closes off the suction area in the secretions canister cover and the device no longer suctions.

9. If the Serres suction bag of the disposable canister system is full: Replace the Serres suction bag (see „4.9.2 Changing the Serres suction bag“, page 68).



If the Serres suction bag is too full, suction material may enter the device or the bacteria filter swells and the device stops suctioning.

WARNING**Risk of infection due to suction material in the device!**

Suction material in the device contaminates the device and reduces its suction capacity. This can infect the patient or user.

- ⇒ Always wear suitable gloves.
- ⇒ Do not use the device.
- ⇒ Contact a technician authorized by
ATMOS MedizinTechnik GmbH & Co. KG.

10. If suction material enters the device: Contact a technician authorized by ATMOS MedizinTechnik GmbH & Co. KG.



Suction material can enter the device if the device tilts over, for example. Reduced suction capacity is an indicator for suction material in the device.

11. Switch off the device (see „4.7 Switching off the device“, page 62).

12. Reprocess the device hygienically (see „5 Hygienic reprocessing“, page 74).

13. Perform a function check (see „6.2 Performing a function check“, page 89).

Result The suction is performed.

4.9 Emptying the canister system

4.9.1 Emptying the reusable secretions canister

This section describes how the reusable secretions canister can be emptied during suction and reused on the same patient. The reusable canister system must be hygienically reprocessed before being used on a new patient (see „5.5 Hygienic reprocessing of the reusable canister system“, page 82).

Requirement

- The device is switched off (see „4.7 Switching off the device“, page 62).
- The reusable suction hose is uncoiled from the suction hose reel and removed from the hose guide.

⚠ WARNING

Risk of infection from escaping suction material!

Suction material can escape the canister system and infect the patient or user.

- ⇒ Always wear suitable gloves.
- ⇒ Remove the canister system carefully.

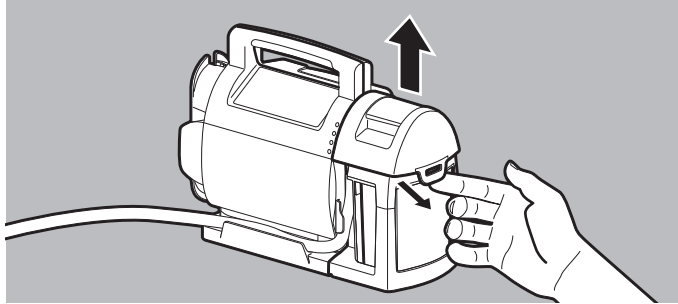

1. Use your finger to unlock the canister latch on the secretions canister cover and remove the reusable secretions canister from the holder.

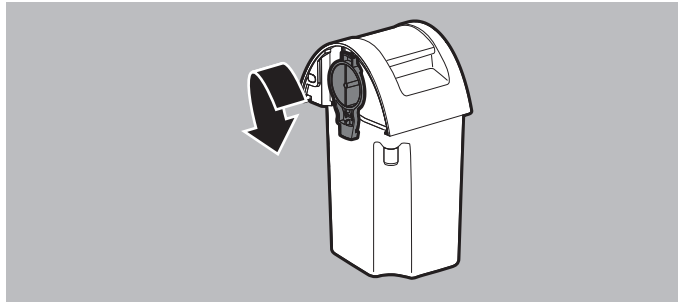

2. Turn the filter holder counterclockwise until the filter holder no longer sits in the detent lug on the reusable secretions canister. When doing so, note: The filter holder must remain in the secretions canister cover.
3. Detach the secretions canister cover carefully from the reusable secretions canister: Tilt the secretions canister cover to the right-hand side or backwards.
4. Dispose of the contents of the reusable secretions canister ([see „10 Disposal“, page 102](#)).
5. Place the secretions canister cover on the reusable secretions canister.

⚠ WARNING

6. Press the cover onto the canister with both hands.

Risk of infection due to reprocessed bacteria filter!

A dried or reprocessed bacteria filter may infect the user or patient.

⇒ Do not reuse the bacteria filter.

7. If the bacteria filter is moist or soiled: Replace the bacteria filter **or** in the case of discoloration, soiling or overflow: Replace the bacteria filter.

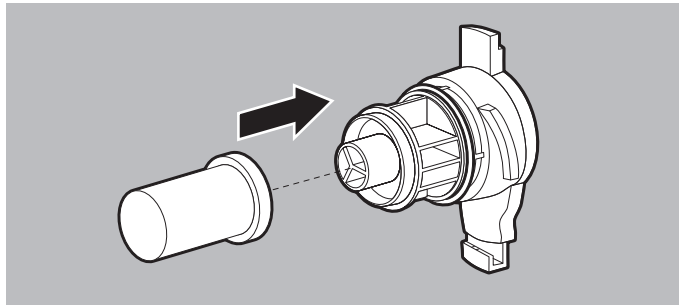

8. Place the new bacteria filter on the filter holder.

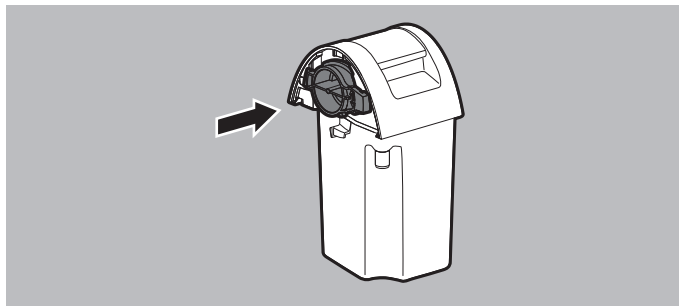

9. Insert the filter holder into the lower section of the secretions canister cover.
When doing so, note: The filter holder must be in a horizontal position.



10. Turn the filter holder as far as it will go clockwise.
When doing so, note: The filter holder must be in a vertical position and click into place in the detent lug on the reusable secretions canister.
11. Insert the reusable canister system into the holder for reusable canister system from above until it audibly clicks into place. The canister latch must engage fully in the holder.
12. Switch on the device (see „4.6 Switching on the device“, page 61).
13. Continue suction (see „4.8 Performing suction“, page 62).

4.9.2 Changing the Serres suction bag

Also observe the intervals of the manufacturer for the long-term treatment of patients.

WARNING

Risk of injury if the hygienic reprocessing specifications are not followed!

Failure to comply with the specifications for hygienic reprocessing can injure the patient and damage the device, accessories and other parts.

⇒ Observe the instructions for use from the manufacturer, Serres.

WARNING

Risk of infection from escaping suction material!

Suction material can escape the canister system and infect the patient or user.

⇒ Always wear suitable gloves.

⇒ Remove the canister system carefully.



1. Detach the disposable suction hose with fingertip control and elbow connector from the Serres suction bag.



2. Close the **PATIENT** connection on the Serres suction bag with the cap.
3. Switch off the device (see „4.7 Switching off the device“, page 62).
4. Pull the Serres suction bag out of the Serres secretions canister using the handle and dispose of it (see „10 Disposal“, page 102).
5. Unfold the new Serres suction bag.

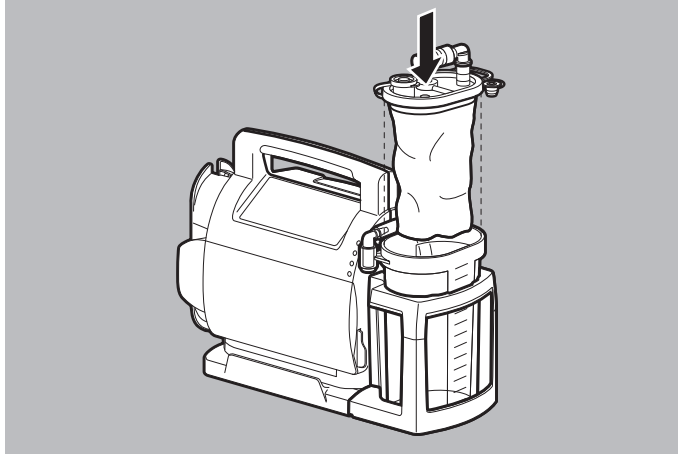

6. Insert the Serres suction bag in the Serres secretions canister. When doing so, note:
 - Only use intact Serres suction bags to protect the device from contamination.
 - The film of the Serres suction bag must be completely inside the Serres secretions canister and the lid of the Serres suction bag must close off the Serres secretions canister tightly.
7. Switch on the device (see [„4.6 Switching on the device“, page 61](#)).
8. Select a vacuum of -0.8 bar and press on the center of the Serres suction bag from above. The suction bag must unfurl.
9. Close the elbow connector on the Serres suction bag with your finger. The Serres suction bag must unfurl completely until it rests on the base and against the sides of the Serres secretions canister.
10. Connect the disposable suction hose to the elbow connector on the Serres suction bag.
11. Continue suction (see [„4.8 Performing suction“, page 62](#)).

4.10 Changing the canister system

The conversion sets for the reusable canister system/disposable canister system can be used to change the device's canister system.

Requirement

- The device is switched off (see „4.7 Switching off the device“, page 62).
- The reusable canister system is removed from the holder for reusable canister system

or

The disposable canister system is removed from the holder for disposable canister system.

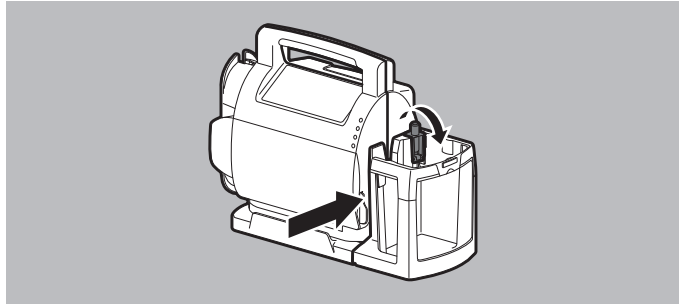

1. On the reusable canister system: Release the lock from the device inlet

or

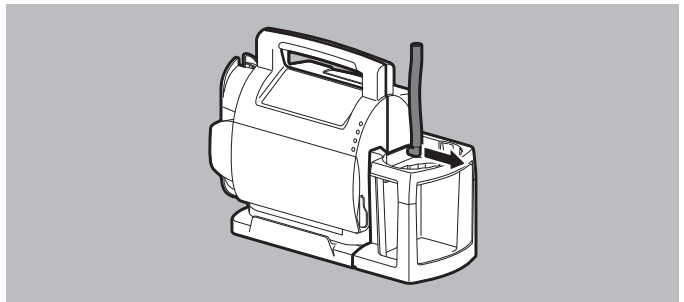

On the disposable canister system: Remove the vacuum tube from the device inlet.

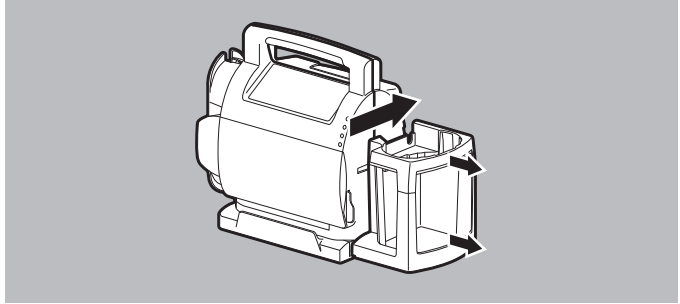

2. Push the holder for canister system to the center and remove it from the device.
3. Install the required holder (see „4.4.4 Installing the holder for canister system“, page 45).
4. Connect the reusable canister system (see „4.4.5 Connecting the reusable canister system“, page 47)
or
Connect the disposable canister system (see „4.4.6 Connecting the disposable canister system“, page 52).

Result The canister system is changed.

4.11 Transporting the device

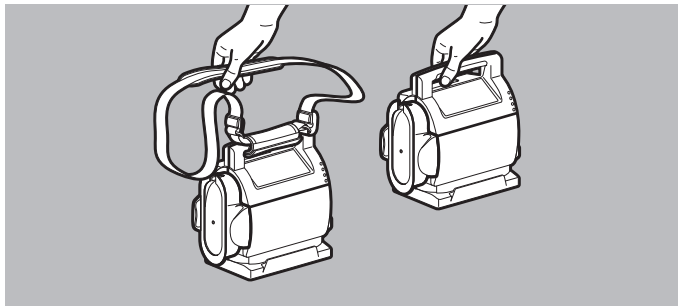

4-3 Using the handle or shoulder strap

You can carry the device in the following ways:

- With the handle on the device
- With the shoulder strap

4.12 After use

1. Switch off the device (see „4.7 Switching off the device“, page 62).
2. Reprocess the device hygienically (see „5 Hygienic reprocessing“, page 74).
3. Perform a function check (see „6.2 Performing a function check“, page 89).

Result The device is ready for use again.

5 Hygienic reprocessing

5.1 General instructions

- **This product may contain disposables. Disposables are intended to be used only once.** So use these items only once and do not reprocess them. Reprocessing disposables may impair the functionality and safety of the product and lead to unforeseeable reactions as a result of ageing, embrittlement, wear, thermal load, the effects of chemical processes, etc.
- Wear suitable gloves for disinfection work (e.g., household or disposable gloves).
- Please refer to the instructions for use supplied with the disinfectant used.
- Also observe the respective instructions for use for the accessories and the other parts.
- The service life of reusable components is a maximum of 50 reprocessing cycles.

5.2 Intervals

Part	Intervals
Device, accessories and other parts	After every patient
Hygiene filter for disposable canister system	<ul style="list-style-type: none"> • Immediately in the case of discoloration, soiling or oversuction <p>or</p> <ul style="list-style-type: none"> • If the vacuum is > -0.2 bar while at maximum suction power with an open suction hose <p>or</p> <ul style="list-style-type: none"> • Every 30 days

5.3 Hygienic reprocessing of the device

WARNING

Risk of infection from suction material on device, accessories and other parts!

Suction material can contaminate the device, accessories and other parts and infect the patient and user.

- ⇒ Always wear suitable gloves.
- ⇒ Reprocess all the parts after use hygienically in accordance with the table in the instructions for use.
- ⇒ Dispose of the suction material in accordance with the regional, national, and internal disposal regulations.
- ⇒ If suction material enters the device: Do not use the device and contact a technician authorized by ATMOS MedizinTechnik GmbH & Co. KG.

WARNING

Risk of injury due to reuse of disposables!

Disposables are intended for single use. Disposable which are reused may be contaminated and/or impaired in their function and therefore cause injury to the patient.

- ⇒ Do not reuse disposables.

CAUTION

Risk of injury due to ingress of liquids!

Liquids in the device or in the power supply accessories may cause an electric shock. This can injure the patient and user, and damage the device and the power supply accessories.

- ⇒ Do not immerse the device or power supply accessories in liquids.
- ⇒ Do not rinse off the device and power-supplying accessories under running water.
- ⇒ Do not wipe the device and power-supplying accessories with a wet cloth.
- ⇒ Do not immerse the device and power-supplying accessories in disinfectant.

1. Switch off the device (see „4.7 Switching off the device“, page 62).
2. Disconnect the device from the power supply.
3. If necessary: Disconnect the power supply accessories from the device.

4. If necessary: Disconnect the following parts from the device:
 - Shoulder strap
 - Accessories bag
 - Protective bag
5. Uncoil the suction hose from the suction hose reel and remove it from the hose guide.

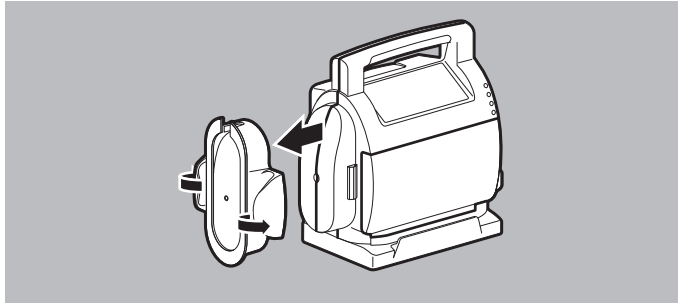

6. If the suction hose reel requires immersion disinfection: Press the two wings of the suction hose reel apart with your thumbs and pull the reel off the device.

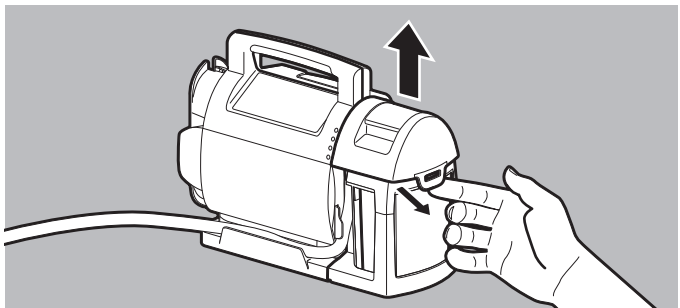

7. On the reusable canister system: Use your finger to release the latch on the secretions canister cover and remove the reusable canister system from its holder

or

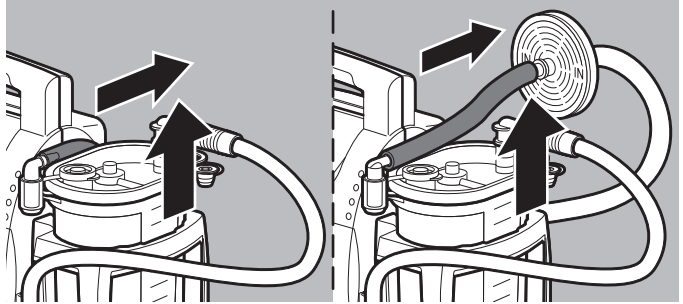

On the disposable canister system: Disconnect the vacuum tube or connection hose for hygiene filter from the angled connector for Serres secretions canister and remove the disposable canister system from its holder.

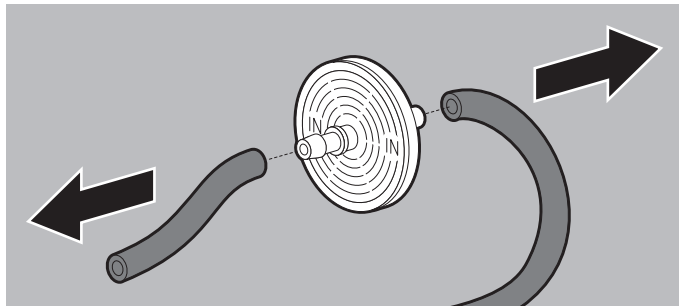

8. When using a hygiene filter for the disposable canister system: Disconnect the vacuum tube and the connection hose from the hygiene filter.
9. Reprocess the reusable canister system hygienically (see „5.5 Hygienic reprocessing of the reusable canister system“, page 82)

or

Reprocess the disposable canister system hygienically (see „5.6 Hygienic reprocessing of the disposable canister system“, page 86).

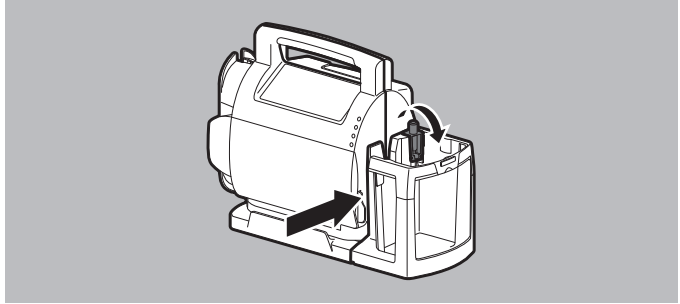

10. On the reusable canister system: Release the lock from the device inlet

or

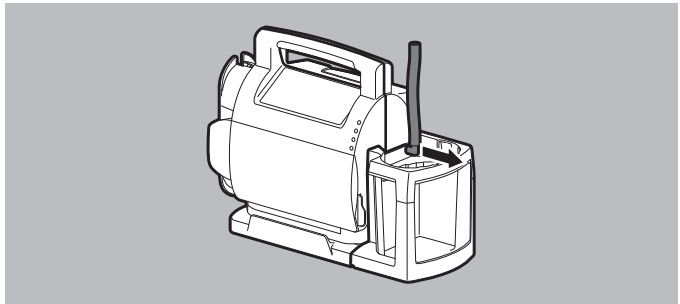

On the disposable canister system: Remove the vacuum tube from the device inlet.

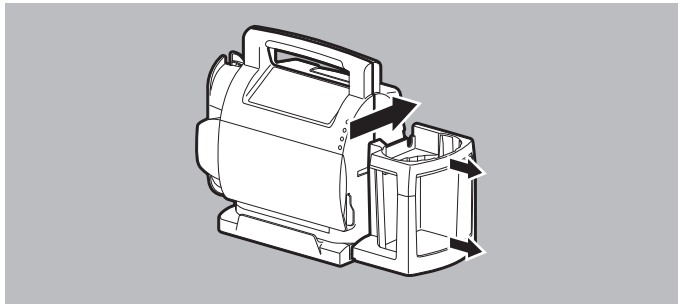

11. Push the holder for canister system to the center and remove it from the device.

12. If the device base requires immersion disinfection: Remove the device base (see „5.4 Removing the device base“, page 81).

13. Carry out hygienic reprocessing of the device, accessories and other parts as specified in the following table:

Part	Cleaning	Disinfection	Thermal disinfection*	Sterilization
Device	Wipe with a damp cloth: Use water	Wipe disinfection (Recommendation: terralin® protect)	Not permitted	Not permitted
Device base	Wipe with a damp cloth: Use water	Wipe disinfection (Recommendation: terralin® protect) / immersion disinfection (Recommendation: GIGASEPT FF (new)) and rinse off with distilled water	Disinfect at 93 °C in a washer-disinfector	Not permitted
Suction hose reel	Wipe with a damp cloth: Use water	Wipe disinfection (Recommendation: terralin® protect) / immersion disinfection (Recommendation: GIGASEPT FF (new)) and rinse off with distilled water	Disinfect at 93 °C in a washer-disinfector	Not permitted
Holder for reusable canister system/ holder for disposable canister system	Wipe with a damp cloth: Use water	Wipe disinfection (Recommendation: terralin® protect) / immersion disinfection (Recommendation: GIGASEPT FF (new)) and rinse off with distilled water	Disinfect at 93 °C in a washer-disinfector	Not permitted
Reusable canister system	Siehe „5.5 Hygienic reprocessing of the reusable canister system“, Seite 82.			
Disposable canister system	Siehe „5.6 Hygienic reprocessing of the disposable canister system“, Seite 86.			

Part	Cleaning	Disinfection	Thermal disinfection*	Sterilization
Wall mounting	Wipe with a damp cloth: Use water or mild soap	Wipe disinfection (Recommendation: terralin [®] protect)	Not permitted	Not permitted
12 V connection cable	Wipe with a damp cloth: Use water or mild soap	Wipe disinfection (Recommendation: terralin [®] protect)	Not permitted	Not permitted
Power supply unit and charger	Wipe with a damp cloth: Use water or mild soap	Wipe disinfection (Recommendation: terralin [®] protect)	Not permitted	Not permitted
Protective bag				
Accessories bag				
Shoulder strap				
Stages of machine cleaning and disinfection in a washer-disinfector according to ISO 15883-1: <ul style="list-style-type: none"> • Rinse for 1 minute with cold, demineralized water • Clean for 5 minutes at 55 °C (± 2 °C) with neodisher[®] MediClean (0.5 % v/v) • Neutralize for 1 minute with demineralized water (1/3 cold water, 2/3 warm water) • Rinse for 1 minute with demineralized water (1/3 cold water, 2/3 warm water) • Thermally disinfect for 5 minutes at 93 °C with demineralized water 				



It is important to observe the instructions for use from the manufacturers of the individual accessories or other parts. They should always be followed.



Some disinfectants can discolor the secretions canister cover of the reusable canister system and the hoses/tubes. This has no effect on the function of the device.

14. If necessary: Install the device base (see „4.4.1 Installing the device base“, page 42).
15. If necessary: Install the battery compartment cover (see „4.4.2 Installing the battery compartment cover“, page 44).
16. Install the holder for canister system (see „4.4.4 Installing the holder for canister system“, page 45).
17. Install the suction hose reel (see „4.4.3 Installing the suction hose reel“, page 45).

18. Install and connect the reusable canister system
(see „4.4.5 Connecting the reusable canister system“,
page 47)

or

Install and connect the disposable canister system
(see „4.4.6 Connecting the disposable canister system“,
page 52).

19. If necessary: Install the following parts:

- Protective bag (see „4.5.4 Attaching the protective bag“,
page 58)
- Accessories bag (see „4.5.5 Attaching the accessories
bag“, page 59)
- Shoulder strap (see „4.5.6 Attaching the shoulder strap“,
page 60)

20. If necessary: Connect the power supply accessories
(see „4.2 Connecting to a power supply“, page 32).

21. Perform a function check (see „6 Function check“, page 89).

Result Hygienically reprocess the device, accessories and other parts.

5.4 Removing the device base

- Requirement*
- The canister system is removed.
 - The holder for canister system is removed.
 - The suction hose reel is removed.
 - The battery compartment cover is removed.

1. Lay the device on the upper part of housing.

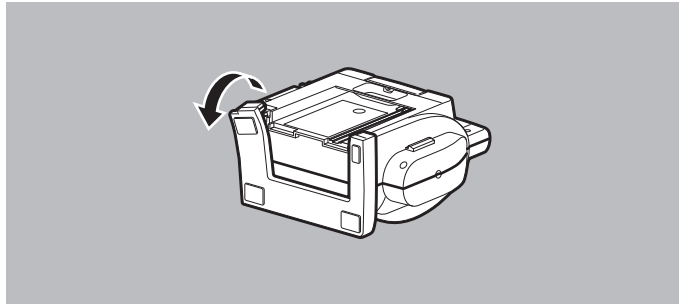

2. Detach the device base from the device starting at the top on the side of the canister system.

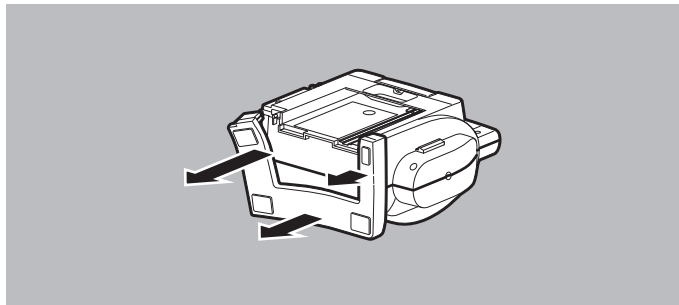

3. Pull the device base from the device, working in a counterclockwise direction.

Result The device base is removed.

5.5 Hygienic reprocessing of the reusable canister system

WARNING

Risk of infection from escaping suction material!

Suction material can escape the canister system and infect the patient or user.

⇒ Always wear suitable gloves.

⇒ Remove the canister system carefully.

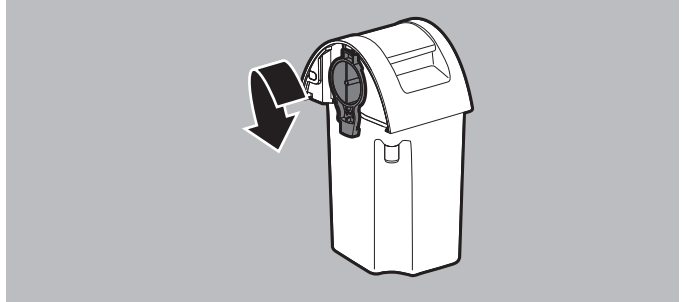

1. Turn the filter holder counterclockwise until the filter holder no longer sits in the detent lug on the reusable secretions canister. When doing so, note: The filter holder must remain in the lower section of the secretions canister cover.
2. Detach the secretions canister cover carefully from the reusable secretions canister: Tilt the secretions canister cover to the right-hand side or backwards.
3. Dispose of the contents of the reusable secretions canister (see „10 Disposal“, page 102).
4. Detach the reusable suction hose with fingertip control from the reusable secretions canister.
5. Detach the fingertip control from the reusable suction hose.
6. Turn the filter holder counterclockwise in the secretions canister cover until it lies horizontally.
7. Pull the filter holder with the bacteria filter out of the secretions canister cover.
8. Pull the bacteria filter off the filter holder and dispose of it (see „10 Disposal“, page 102).
9. Pull the O-ring off the filter holder.
10. Remove the float ball from the lower section of the secretions canister cover.

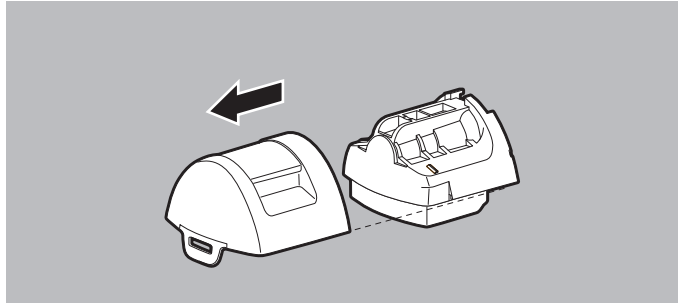

11. Pull the upper section of the secretions canister cover off the lower section of the secretions canister cover.
12. Carry out hygienic reprocessing of the individual components of the reusable canister system as specified in the following table:

Part	Cleaning	Disinfection	Thermal disinfection*	Sterilization**
Reusable secretions canister	Rinse off with clear water and clean with a brush/cloth	Immersion disinfection (Recommendation: GIGASEPT FF (new))	Disinfect at 93 °C in a washer-disinfector	If necessary, steam sterilize at 134 °C, 3 x fractionated pre-vacuum method, sterilization time 5 mins with devices according to EN 285
Filter holder	Rinse off with clear water and clean with a brush/cloth	Immersion disinfection (Recommendation: GIGASEPT FF (new))	Disinfect at 93 °C in a washer-disinfector	If necessary, steam sterilize at 134 °C, 3 x fractionated pre-vacuum method, sterilization time 5 mins with devices according to EN 285
O-ring	Wipe with a damp cloth: Use water	immersion disinfection (Recommendation: GIGASEPT FF (new))	Disinfect at 93 °C in a washer-disinfector	Not permitted
Bacteria filter	Disposable, do not reuse			

Part	Cleaning	Disinfection	Thermal disinfection*	Sterilization**
Secretions canister cover (upper section)	Rinse off with clear water and clean with a brush/cloth	Immersion disinfection (Recommendation: GIGASEPT FF (new))	Disinfect at 93 °C in a washer-disinfector	If necessary, steam sterilize at 134 °C, 3 x fractionated pre-vacuum method, sterilization time 5 mins with devices according to EN 285
Secretions canister cover (lower section)	<ul style="list-style-type: none"> Rinse off with clear water and clean with a brush/cloth Clean the float ball guide with a round brush 	Immersion disinfection (Recommendation: GIGASEPT FF (new))	Disinfect at 93 °C in a washer-disinfector	If necessary, steam sterilize at 134 °C, 3 x fractionated pre-vacuum method, sterilization time 5 mins with devices according to EN 285
Float ball	Rinse off with clear water and clean with a brush/cloth	Immersion disinfection (Recommendation: GIGASEPT FF (new))	Disinfect at 93 °C in a washer-disinfector	If necessary, steam sterilize at 134 °C, 3 x fractionated pre-vacuum method, sterilization time 5 mins with devices according to EN 285
Reusable suction hose	Rinse out with warm, clear water for at least 10 seconds	Immersion disinfection (Recommendation: GIGASEPT FF (new))	Disinfect at 93 °C in a washer-disinfector	If necessary, steam sterilize at 134 °C, 3 x fractionated pre-vacuum method, sterilization time 5 mins with devices according to EN 285
Fingertip control	Disposable, do not reuse			
Stages of machine cleaning and disinfection in a washer-disinfector according to ISO 15883-1: <ul style="list-style-type: none"> Rinse for 1 minute with cold, demineralized water Clean for 5 minutes at 55 °C (± 2 °C) with neodisher® MediClean (0.5 % v/v) Neutralize for 1 minute with demineralized water (1/3 cold water, 2/3 warm water) Rinse for 1 minute with demineralized water (1/3 cold water, 2/3 warm water) Thermally disinfect for 5 minutes at 93 °C with demineralized water 				
** Sterilization:* The service life of reusable elements is designed for a maximum of 50 reprocessing cycles.				

13. Allow the individual components of the reusable canister system to dry.

Result The reusable canister system is hygienically reprocessed.

5.6 Hygienic reprocessing of the disposable canister system

⚠ WARNING

Risk of injury if the hygienic reprocessing specifications are not followed!

Failure to comply with the specifications for hygienic reprocessing can injure the patient and damage the device, accessories and other parts.

⇒ Observe the instructions for use from the manufacturer, Serres.

⚠ WARNING

Risk of infection from escaping suction material!

Suction material can escape the canister system and infect the patient or user.

⇒ Always wear suitable gloves.

⇒ Remove the canister system carefully.

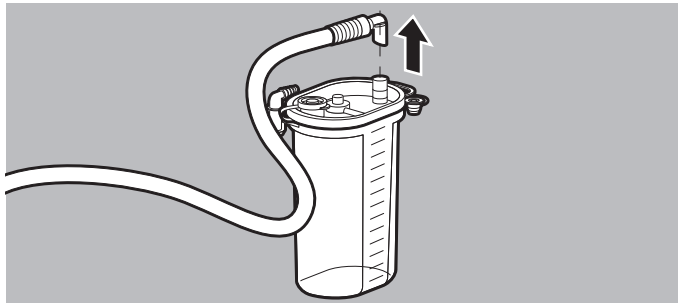

1. Detach the disposable suction hose with fingertip control and elbow connector from the Serres suction bag.

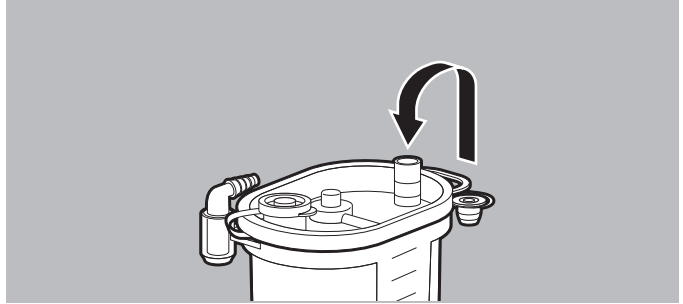

2. Close the **PATIENT** connection on the Serres suction bag with the cap.
3. Pull the Serres suction bag out of the Serres secretions canister using the handle and dispose of it (see „10 Disposal“, page 102).
4. Detach the angled connector from the Serres secretions canister.
5. Carry out hygienic reprocessing of the individual components of the Serres secretions canister as specified in the following table:

Part	Cleaning	Disinfection	Thermal disinfection	Sterilization
Serres secretions canister	Clean in warm water with a mild cleaning agent	Wipe disinfection (Recommendation: terralin® protect) / immersion disinfection (Recommendation: GIGASEPT FF (new) and rinse off with distilled water	Rinse at up to 95 °C	Steam sterilize at 121 °C (for a minimum of 20 mins with devices which comply with EN 285)

Part	Cleaning	Disinfection	Thermal disinfection	Sterilization
Angled connector for Serres secretions canister	Clean in warm water with a mild cleaning agent	Wipe disinfection (Recommendation: terralin [®] protect) / immersion disinfection (Recommendation: GIGASEPT FF (new) and rinse off with distilled water)	Rinse at up to 95 °C	Steam sterilize at 121 °C (for a minimum of 20 mins with devices which comply with EN 285)
Elbow on Serres suction bag	Disposable, do not reuse			
Serres suction bag	Disposable, do not reuse			
Vacuum tube	Clean in warm water with a mild cleaning agent	Rinse for 10 s with clear water. After every suction procedure or at least 1 x per day: Wipe disinfection (Recommendation: terralin [®] protect) / immersion disinfection (Recommendation: GIGASEPT FF (new) and rinse off with distilled water)	Not permitted	Not permitted
Disposable suction hose with fingertip control	Disposable, do not reuse			
Hygiene filter				
Connection hose				

6. Allow the individual components of the Serres secretions canister to dry.

Result The Serres secretions canister is hygienically reprocessed.

6 Function check

6.1 Intervals

Carry out a function check at regular intervals:

ACCUVAC Pro

- Before and after every use
- After every hygienic reprocessing
- Every 6 months (if the device is not used)

ACCUVAC Lite

- Before and after every use
- After every hygienic reprocessing
- Every 3 months (if the device is not used): Check the battery status and charge the battery if necessary.
- Every 6 months (if the device is not used)

6.2 Performing a function check

6.2.1 Preparing for the function check



CAUTION

Risk of injury due to device which is damaged or not ready for use!

Operation of a device which is damaged or has failed a function check may result in injury to the patient.

⇒ Only use undamaged devices.

⇒ Only operate the device after it passes the function check.

⇒ Have the damaged device repaired.

Requirement

- There is a canister system installed.
- There is a suction hose connected to the canister system.

1. Check the following parts for external damage:
 - Device
 - Power supply accessories
 - Hoses/tubes
 - Canister system

If necessary: Replace parts.
2. If available: Connect the power supply unit and charger to the line power.
If the pilot lamp does not light up: Replace the power supply unit and charger.
3. Check the secure, correct positioning of the hoses/tubes and canister system.
If necessary: Connect the hoses/tubes and canister system correctly.
4. Check the hook and loop fastener on the shoulder strap.
If the hook and loop fastener is damaged or contaminated with lint: Replace the shoulder strap.

Result The function check is ready.

6.2.2 Performing a function check (ACCUVAC Pro)

Requirement The function check is ready (see „6.2.1 Preparing for the function check“, page 89).

1. If necessary: Connect the fingertip control to the suction hose.
2. Close the secondary air inlet on the fingertip control with the cap.
3. Close the opening at the end of the fingertip control with your thumb.
4. Hold the  test button down for approx. 3 seconds until an audible signal sounds.
The battery status indicator displays the current battery status.
5. If necessary: Charge battery (see „4.3.2 Charging the battery“, page 34).

The automatic function check starts with the audible signal and all the LEDs on the control panel light up briefly. The LEDs of the On/Off button (①) flash during the automatic function check. The automatic function check includes the following sequence of tests:

- Leaktightness
 - System
 - Battery
6. To cancel the function check: Press the test button (⏸)

or

Press the On/Off button (①).

7. Proceed with the device according to the following table:

Display	Meaning	Action
<ul style="list-style-type: none"> • An audible signal sounds.  <ul style="list-style-type: none"> • The three green status LEDs of the function check light up. 	Function check passed	Use device without restriction.
<ul style="list-style-type: none"> • Two signal tones sound. • The red status LED lights up and one or more green status LEDs of the failed tests flash. • The green status LEDs of the passed tests light up. 	Function check failed	Take action (see „6.2.3 Failed function check (ACCUVAC Pro)“, page 92).

8. If necessary: Switch off the device (see „4.7 Switching off the device“, page 62).

Result The automatic function check is complete.

6.2.3 Failed function check (ACCUVAC Pro)

⚠ CAUTION

Risk of injury due to device which is damaged or not ready for use!

Operation of a device which is damaged or has failed a function check may result in injury to the patient.



⇒ Only use undamaged devices.

⇒ Only operate the device after it passes the function check.

⇒ Have the damaged device repaired.

Requirement The automatic function check has been failed.

1. Proceed with the device according to the following table:

Display	Failed test	Rectification
<ul style="list-style-type: none"> The red status LED lights up.  <ul style="list-style-type: none"> The upper green status LED flashes. 	Battery	Replace battery.
<ul style="list-style-type: none"> The red status LED lights up.  <ul style="list-style-type: none"> The middle green status LED flashes. 	System	Have the device repaired.
<ul style="list-style-type: none"> The red status LED lights up.  <ul style="list-style-type: none"> The lower green status LED flashes. 	Leaktightness	Check the connections and canister system. If necessary: Have the device repaired.

2. Repeat the function check.

3. If the automatic function check has been failed again: Have the device repaired.

6.2.4 Performing a function check (ACCUVAC Lite)

Requirement The function check is ready (see „6.2.1 Preparing for the function check“, page 89).

1. Switch on the device (see „4.6 Switching on the device“, page 61).

Requirement:

- All the LEDs on the control panel light up.
 - The LEDs of the battery status indicator light up to show the battery status.
2. Check the battery status on the battery status indicator.
If necessary: Charge battery (see „4.3 Using the rechargeable battery“, page 33).
 3. If necessary: Connect the fingertip control to the suction hose.
 4. Close the secondary air inlet with the cap.
 5. Close the opening at the end of the fingertip control with your thumb.
 6. Select vacuum of -0.8 bar.

Requirement:

The device attains the maximum vacuum of -0.8 bar within 20 seconds.



The vacuum pump does not stop once the device attains the maximum vacuum of -0.8 bar.

7. If the device does not satisfy the requirements: Rectify the fault (see „7 Faults“, page 94).
8. Repeat the function check.
9. If the device still does not satisfy the requirements: Have the device repaired.
10. Switch off the device (see „4.7 Switching off the device“, page 62).

Result The manual function check is complete and the device is ready for use.

7 Faults

If you are unable to eliminate faults immediately with the aid of the table, you should contact ATMOS MedizinTechnik GmbH & Co. KG or your authorized dealer to have the device repaired. To avoid serious damage, do not continue using the device.

WARNING

Risk of infection from suction material on device, accessories and other parts!

Suction material can contaminate the device, accessories and other parts and infect the patient and user.

⇒ Always wear suitable gloves.

⇒ Reprocess all the parts after use hygienically in accordance with the table in the instructions for use.

⇒ If suction material enters the device: Reprocess the device hygienically and have it repaired.

7.1 Device

The following faults apply for both devices. Faults or causes of faults which only apply for one device are marked with "(ACCUVAC Pro only)" or "(ACCUVAC Lite only)".

Fault	Cause	Remedy
Device cannot be switched on	Battery not connected	Check the battery connection.
	Battery empty	<ul style="list-style-type: none"> • Charge battery. • Replace battery.
	Device not connected to the power supply	Check the power supply connections.
	Fuse defective (ACCUVAC Lite only)	Have the device repaired.
	Device defective	Have the device repaired.

Fault	Cause	Remedy
Device cannot be charged	Battery temperature higher than permissible charging temperature due to extended use	Allow device to cool.
	Device not connected to the power supply	Check the power supply connections.
	Voltage from 12 V DC power source too low	Connect 12 V DC power source with 12 V to 13.8 V.
	Battery temperature outside of permissible charging temperature range	Move battery to cooler or warmer ambient temperature, as appropriate.
	Positive and negative of the 12 V on-board power supply reversed	Check positive and negative on 12 V on-board power supply.
	12 V connection cable defective	Replace 12 V connection cable.
	Battery not connected	Check the battery connection.
	Power supply unit and charger defective	Replace the power supply unit and charger.
	Battery deeply discharged	Replace battery.
	Fuse defective (ACCUVAC Lite only)	Have the device repaired.
	Device defective	Have the device repaired.
Device does not attain the set vacuum or create a vacuum at all	Opening on the end of the fingertip control not closed	Close the opening on the end of the fingertip control and repeat the function check.
	Secondary air inlet on the fingertip control not closed with the cap	Close the secondary air inlet with the cap and repeat the function check.
	Canister system is leaking or is not correctly connected	Check the canister system and hoses.
	Device operated at high altitude or low ambient pressure	No remedy possible, as problem is due to physical laws.
	Device leaking	Have the device repaired.

Fault	Cause	Remedy
Suction capacity too low	Canister system not connected correctly	Check the connections on the canister system.
	Canister system leaking	
	Hoses/tubes kinked	Check hoses/tubes.
	Bacteria filter blocked	Replace the bacteria filter.
	Float ball closes the suction area in the secretions canister cover (reusable canister system)	Check the reusable canister system: Switch off the device. Remove the reusable canister system and install it again. The float ball is in the lower position again.
	Battery empty and device not connected to the power supply	Charge battery.
	Battery defective	Replace battery.
	Suction material within the device	Have the device repaired.
Device defective	Have the device repaired.	
Battery compartment cover cannot be closed	Battery incorrectly inserted	Insert battery correctly.
Device switches off after 60 mins (ACCUVAC Pro only)	Device's autoprotection system	Allow the device to cool for 2 hours (depending on ambient conditions).
Device switches off after < 60 mins (ACCUVAC Pro only)	Battery empty	Charge battery.
	Battery temperature too high due to operation at high ambient temperatures and at the highest suction level	Allow the device to cool and select a lower suction level.
All green status LEDs on the battery status indicator flash at the same time during operation (ACCUVAC Pro only)	Battery not inserted	Insert battery.
	Battery not connected correctly	Check the battery connection.
	Battery from other manufacturer used	Only use the accessories listed in these instructions for use.
	No communication between battery and device	Replace battery. If the fault persists: Have the device repaired.
	Battery defective	
Device defective	Have the device repaired.	
When the device is switched on, the red status LED flashes quickly for 5 seconds and a recurring audible signal sounds for 5 seconds (ACCUVAC Pro only)	Device may not be ready for use	Perform a function check (see 6.2, p. 89).

Fault	Cause	Remedy
When the device is switched on, the bottom green status LED and the red status LED flash quickly and an audible signal sounds every 5 seconds (ACCUVAC Pro only)	Battery not sufficiently charged and the device is not connected to a power supply	<ul style="list-style-type: none"> • Charge battery. • Connect the device to the power supply.
When the device is switched on, all green status LEDs and the red status LED flash for 5 seconds and a recurring audible signal sounds for 5 seconds (ACCUVAC Pro only)	The battery has reached the end of its service life	Perform a function check (see 6.2, p. 89).
Battery fails to charge fully despite a charging time of > 14 hours (top green status LED of the battery status indicator does not light up) (ACCUVAC Lite only)	Unsuitable power supply unit and charger	Use the WM 2620 power supply unit and charger.
	Battery defective	Replace battery.
Red status LED of the battery status indicator lights up if the battery is fully charged (ACCUVAC Lite only)	Battery defective	Replace battery.
Two LEDs above the vacuum levels flash green (ACCUVAC Pro only)	No fault: <ul style="list-style-type: none"> • The higher LED flashes green because this vacuum was selected. • The lower LED flashes green because this vacuum level has nearly been reached). 	—

7.2 Power supply unit and charger

Fault	Cause	Remedy
Pilot lamp does not light up	Power supply unit and charger defective	Replace the power supply unit and charger.

8 Maintenance

8.1 General instructions

- The device, accessories and other parts do not require any maintenance. Observe the intervals for the function check (see „6 Function check“, page 89).
- Repeat tests:
 - Repeat testing to assess safety every 24 months.
 - Recommended: Inspection according to the manufacturer’s specifications.
- Maintenance work such as inspections and repairs must only be carried out by WEINMANN Emergency, authorized by ATMOS MedizinTechnik GmbH & Co. KG, or other expressly authorized technician.

8.2 Sending parts for inspection and repair

WARNING

Risk of infection from contaminated parts!

The device, accessories and other parts may be contaminated and infect the technicians with bacteria and viruses. Parts sent for inspection and repair which are visibly contaminated will be disposed of by WEINMANN Emergency, authorized by ATMOS MedizinTechnik GmbH & Co. KG, or other expressly authorized technician at the sender’s expense.

⇒ Clean and disinfect parts before sending.

⇒ Do not send parts which are potentially contaminated.

1. Disassemble parts.
2. Clean and disinfect parts (see „5.3 Hygienic reprocessing of the device“, page 75).
3. Send parts to WEINMANN Emergency, authorized by ATMOS MedizinTechnik GmbH & Co. KG, or other authorized technician.

8.3 Changing the release catch

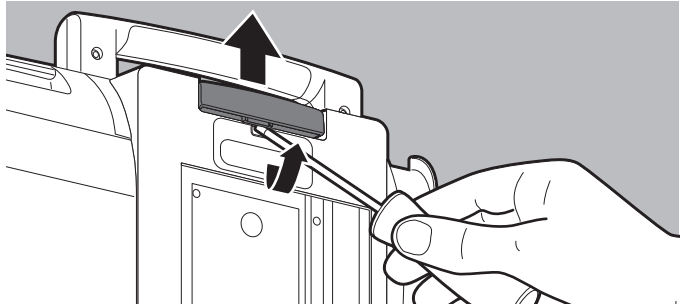

1. Lift the release catch up carefully in the center using a screwdriver and remove.

When doing so, note: Take care not to lose the springs below the release catch.

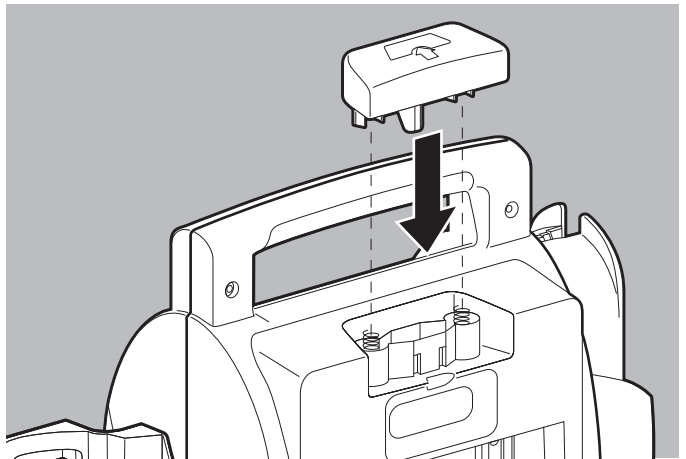

2. Place the new release catch on the springs.
3. Push the release catch down until it audibly clicks into place.

Result The release catch is replaced.

8.4 Replacing the cap for adjusting knob of the vacuum regulator

Required tools Watchmaker's screwdriver

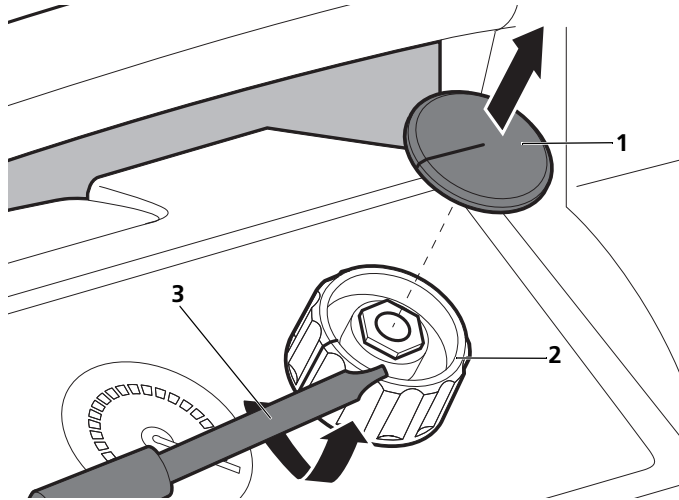

1. Detach the cap (1) from the adjusting knob (2) of the vacuum regulator with the watchmaker's screwdriver (3).

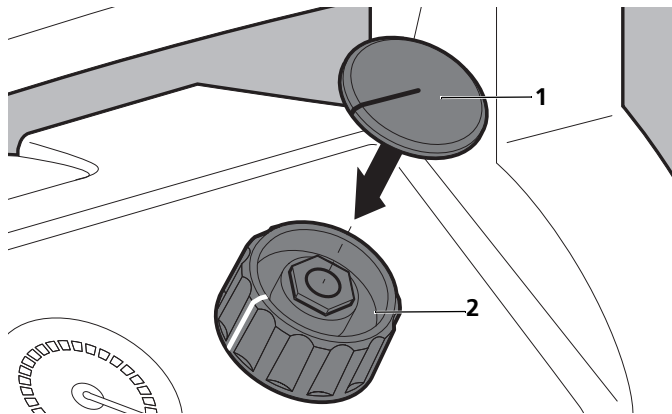

2. Place the cap (1) on the adjusting knob (2) of the vacuum regulator.
When doing so, note: The black line on the cap must line up with the white line on the adjusting knob.

9 Storage

9.1 General instructions

- Store the device under the prescribed ambient conditions (see „11.1 Technical data“, page 104).
- Always store the device with the battery fully charged.
- To ensure that the battery reaches its maximum service life, the battery must not discharge too much even during storage. At least 2 green status LEDs must light up on the battery status indicator.
- Charge the battery when stored for a long time:

ACCUVAC Pro

Every 6 months.

ACCUVAC Lite

Every 3 months.

- Do not store the battery in direct sunlight or close to heaters.
- The battery should ideally be stored in a temperature range of 8 °C to 15 °C.
- Observe the manufacturer's instructions for storing accessories and other parts.

9.2 Storing the device

1. Switch off the device (see „4.7 Switching off the device“, page 62).
2. If necessary: Disconnect the device from the power supply.
3. Clean and disinfect the device (see „5.3 Hygienic reprocessing of the device“, page 75).
4. Store the device with the battery in a dry place.

Result The device and battery are stored in a dry place.

10 Disposal

10.1 Electronic waste

CAUTION



Environmental hazard from electronic waste!

Electronic waste poses an environmental hazard and must be disposed of properly.

⇒ Do not dispose of electronic waste in household waste.

⇒ Contact WEINMANN Emergency, authorized by ATMOS MedizinTechnik GmbH & Co. KG, or an authorized, certified electronic waste company for proper disposal.

The following products are categorized as electronic waste:

- Cleaned and disinfected device

Exception: If the inside of a device is contaminated with suction material, consult a certified specialist disposal company.

- 12 V connection cable
- Power supply unit and charger

The device packaging (cardboard box and inserts) can be disposed of as waste paper.

10.2 Battery



Do not dispose of used batteries in the household waste. Contact WEINMANN Emergency, authorized by

ATMOS MedizinTechnik GmbH & Co. KG, or a public waste disposal authority.

10.3 Reusable canister system

Reprocess the reusable canister system hygienically. Dispose of the reusable canister system as household waste or recycle it.

10.4 Disposable canister system

Reprocess the disposable canister system hygienically. Dispose of the disposable canister system in accordance with the national, regional, or internal recycling regulations. The Serres suction bag is a disposable product and must not be reused.

10.5 Suction material

Dispose of the suction material (e.g., secretions, blood, or contaminated parts) as follows:

- In Germany: In accordance with the requirements of the guidelines for disposal of waste from healthcare facilities (LAGA notice). Observe the local disposal regulations.
- Internationally: In accordance with the provisions in the individual countries.

10.6 Bags/cases

Reprocess the bags/cases hygienically. Dispose of them as household waste.

10.7 Contaminated parts

Do not dispose of contaminated parts in household waste. Use an approved, certified special waste disposal company for proper disposal of contaminated parts.

11 Appendix

11.1 Technical data

11.1.1 Technical data on device

Specification	ACCUVAC Pro	ACCUVAC Lite
Power	12 V DC nominal (10 V min., 15 V max.) at charging interface, via the power supply unit and charger	
Current consumption	Max. 3.7 A	
Power rating	45 W max.	
Pump	Vacuum pump (membrane pump), 1 head	
Suction capacity at the device inlet (without canister system) at -0.8 bar, with charged battery, and at 21 °C/1013 hPa (calculated with 1 l buffer canister)	34 l/min ± 4 l/min	26 l/min ± 4 l/min
Suction capacity at reusable canister system inlet at -0.8 bar, with fully charged battery, and at 21 °C/1013 hPa	30 l/min ± 3 l/min	23 l/min ± 3 l/min
Maximum attainable vacuum	0.8 bar* ± 5 % or 80 % of air pressure	0.8 bar* +0.15 bar/-0.06 bar or 80 % of air pressure
Vacuum setting	Via predefined levels: -0.1 bar, -0.2 bar, -0.5 bar and -0.8 bar, electronically regulated	Via infinitely adjustable vacuum regulator: -0.1 bar to -0.8 bar
Vacuum display	Via LEDs on the control panel	Gauge up to -1 bar max., class of accuracy 2.5 (2.5 %)
Display	Via LEDs on the control panel: On/Off, selected vacuum, actual vacuum, battery status indicator, warning (red status LED)	Via LEDs on the control panel: On/Off, battery status indicator, warning (red status LED)
Operating mode	Short-term operation 60 mins on, 120 mins off	Short-term operation 45 mins on, 90 mins off
Volume	< 60 dB(A) Average sound pressure level 1 m away and at -0.8 bar	

Specification	ACCUVAC Pro	ACCUVAC Lite
Ambient conditions: Transportation/ storage <ul style="list-style-type: none"> • Temperature • Humidity without condensation • Air pressure 	-40 °C to +70 °C 5 % to 95 % 540 hPa to 1100 hPa	
Ambient conditions: Operation <ul style="list-style-type: none"> • Temperature • Humidity without condensation • Air pressure 	-5 °C to +50 °C 5 % to 95 % 540 hPa to 1100 hPa	
Max. operating height (above sea level)	5,000 m	
Pollution category	1	
Overvoltage category	II	
Dimensions (H x W x D) <ul style="list-style-type: none"> • With reusable canister system • With Serres disposable canister system 	37 x 27.7 x 14.6 cm 37 x 27.7 x 14.6 cm	
Weight <ul style="list-style-type: none"> • Device with battery but without canister system and holder • With reusable canister system • With Serres disposable canister system 	3.65 kg 1.00 kg 0.65 kg	4.6 kg 1.00 kg 0.65 kg
Mounting	Compatible with wall mounting WM 15208	
Regular checks	Repeat testing to assess safety every 24 months. Recommended: Inspection according to the manufacturer's specifications.	
Protection class against electric shock (according to EN 60601-1)	II (line power and battery operation)	
Applied part classification	Applied part Type BF 	
Classification as per EN ISO 10079-1	High vacuum/high flow	
Type of protection	IP34D	
CE marking	CE 0124	

Specification	ACCUVAC Pro	ACCUVAC Lite
Article number (REF)	WM 11602	WM 11702
Charging process: <ul style="list-style-type: none"> • Temperature range • Humidity • Air pressure 	0 °C to +40 °C 5 % to 95 % relative humidity without condensation 540 hPa to 1100 hPa	-5 °C to +50 °C 5 % to 95 % relative humidity without condensation 540 hPa to 1100 hPa
Repeated technical safety checks (STKs, only in Germany)	Not applicable	

*1 bar = 100 kPa

CE 0124

Subject to alterations in design

11.1.2 Technical data for battery

Specification	ACCUVAC Pro	ACCUVAC Lite
Type	Li-ion	Lead
Dimensions (W x H x D)	4.3 x 7.3 x 7.5 cm	6.7 x 13.4 x 6.7 cm
Weight	0.4 kg	1.15 kg
Nominal capacity	Min. 4.3 Ah	3.4 Ah
Rated voltage	14.4 V	12 V nominal
Charging time	Battery status 80 %: 3 h 45 mins at 20 °C while not in operation; battery status 100 %: approx. 5 h 40 mins Automatic changeover to trickle charging	Battery status 80 %: 2 h 40 mins Battery status 100 %: 14 h Automatic changeover to trickle charging
Charging interval in long-term storage	Every 6 months	Every 3 months
Battery run time in continuous operation with fully charged/new battery (> 20 l/min, setting -0.8 bar)	85 mins at -5 °C 85 mins at +21 °C 42 mins at +50 °C	23 mins at -5 °C 40 mins at +21 °C 40 mins at +50 °C
Service life	Approx. 500 charging cycles in approx. 4 years	400 charging cycles in approx. 3 years
Display	Battery status indicator during operation and charging	
Typical battery life*	-0.2 bar: 200 mins -0.5 bar: 140 mins -0.8 bar: 85 mins	-0.2 bar: 40 mins -0.5 bar: 40 mins -0.8 bar: 40 mins

*Measured at +21 °C, continuous use, without charging the battery and with free air flow

11.1.3 Technical data for power supply unit and charger

Specification	ACCUVAC Pro	ACCUVAC Lite
Dimensions (W x H x D)	13 x 3.8 x 6 cm	
Weight	280 g	
Ambient conditions: Transportation/ storage		
Temperature	-40 °C to +70 °C	
Humidity without condensation	10 % to 95 %	
Air pressure	700 hPa to 1100 hPa	
Ambient conditions: Operation		
Temperature	0 °C to +40 °C	
Humidity without condensation	10 % to 90 %	
Air pressure	700 hPa to 1100 hPa	
Electrical connection	100 V AC to 240 V AC 50 Hz to 60 Hz	
Current consumption	Max. 1.1 A	
Nominal output	13.8 V DC, 3.5 A	
Protection class against electric shock (according to EN 60601-1)	II	
Applied part classification	Applied part Type BF 	
Type of protection	IP40	
Length of output line	1.8 m	
Length of power supply cable	Approx. 2 m	

CE 0124

Subject to alterations in design

11.1.4 Technical data for reusable canister system

Specification	Reusable canister system
Capacity	1000 ml
Connection reusable suction hose	Ø 10 mm ID
Reusable suction hose Diameter Length	Ø 10 mm ID 1300 mm
Connection to the electric suction device	Direct connection (without intermediate hose)
Bacteria filter	Hydrophobic bacteria filter cartridge for use in secretions canister cover, disposable
Separation efficiency of bacteria filter	> 99.9 %

11.1.5 Technical data for disposable canister system

Specification	Disposable canister system
Capacity	1000 ml
Connection disposable suction hose	Ø 7 mm ID
Disposable suction hose Diameter Length	Ø 7 mm ID 1800 mm
Connection to the electric suction device	Via vacuum tube (intermediate hose)
Bacteria filter	Integrated in the Serres suction bag
Hygiene filter Type of filter Bacterial filtration efficiency (BFE) Viral filtration efficiency (VFE) Total efficiency Filter class Reduction in suction capacity	Hydrophobic bacteria and virus filter 99.999778 % 99.73 % > 99.95 % H13 (High-Efficiency Particulate Air/Arrestance) 3 l/min to 4 l/min

11.1.6 Technical data for shoulder strap

Specification	Shoulder strap
Maximum weight	7 kg

11.1.7 Technical data on electromagnetic compatibility (EMC)

Medical electrical equipment is subject to special precautions in relation to electromagnetic compatibility (EMC). It must be installed and put into operation in accordance with the EMC information contained in the accompanying documentation.

Separation distances

Recommended separation distances between portable and mobile RF communications equipment and ACCUVAC Pro/ACCUVAC Lite			
ACCUVAC Pro/ACCUVAC Lite are intended for use in an electromagnetic environment in which the radiated RF disturbances are controlled. The customer or user of the ACCUVAC Pro/ACCUVAC Lite can avoid electromagnetic interference by maintaining a minimum distance between portable and mobile RF communications equipment (transmitters) and the ACCUVAC Pro/ACCUVAC Lite (as recommended below, according to the maximum output power of the communications equipment).			
Rated maximum output power of the RF device in W	Separation distance depending on transmission frequency in m		
	150 kHz - 80 MHz $d = [0.35] \sqrt{P}$	80 MHz - 800 MHz $d = [0.35] \sqrt{P}$	800 MHz - 2.5 GHz $d = [0.75] \sqrt{P}$
0.01	0.035	0.035	0.07
0.1	0.11	0.11	0.22
1	0.35	0.35	0.7
10	1.1	1.1	2.2
100	3.5	3.5	7.0

Further technical data can be requested from WEINMANN Emergency.

11.2 Scope of supply

11.2.1 Standard scope of supply ACCUVAC Pro

ACCUVAC Pro without canister system

WM 11601

Designation	Article number
ACCUVAC Pro	WM 11602
Rechargeable battery, lithium-ion	WM 11603
Battery compartment cover	WM 11604
ACCUVAC Pro/ACCUVAC Lite instructions for use EN	WM 68161

ACCUVAC Pro with disposable canister system

WM 11605

Designation	Article number
ACCUVAC Pro	WM 11602
Rechargeable battery, lithium-ion	WM 11603
Battery compartment cover	WM 11604
Holder for disposable canister system	WM 11754
Vacuum tube for disposable canister system	WM 11761
Serres secretions canister, 1000 ml	WM 10775
Suction hose with fingertip control	WM 10778
Serres suction bag, 1000 ml, with bacteria filter and solidifying agent	WM 10774
ACCUVAC Pro/ACCUVAC Lite instructions for use EN	WM 68161

ACCUVAC Pro with disposable canister system and power supply unit and charger for 100–240 V

WM 11635

Designation	Article number
ACCUVAC Pro	WM 11602
Rechargeable battery, lithium-ion	WM 11603
Battery compartment cover	WM 11604
Holder for disposable canister system	WM 11754
Vacuum tube for disposable canister system	WM 11761
Serres secretions canister, 1000 ml	WM 10775
Power supply unit and charger	WM 2620

Designation	Article number
Suction hose with fingertip control	WM 10778
Serres suction bag, 1000 ml, with bacteria filter and solidifying agent	WM 10774
ACCUVAC Pro/ACCUVAC Lite instructions for use EN	WM 68161

ACCUVAC Pro with disposable canister system and accessories bag **WM 11645**

Designation	Article number
ACCUVAC Pro	WM 11602
Rechargeable battery, lithium-ion	WM 11603
Battery compartment cover for accessories bag	WM 11614
Holder for disposable canister system	WM 11754
Vacuum tube for disposable canister system	WM 11761
Serres secretions canister, 1000 ml	WM 10775
Accessories bag	WM 11690
Suction hose with fingertip control	WM 10778
Serres suction bag, 1000 ml, with bacteria filter and solidifying agent	WM 10774
ACCUVAC Pro/ACCUVAC Lite instructions for use EN	WM 68161

ACCUVAC Pro with reusable canister system **WM 11600**

Designation	Article number
ACCUVAC Pro	WM 11602
Rechargeable battery, lithium-ion	WM 11603
Battery compartment cover	WM 11604
Reusable canister system, 1000 ml, with canister holder	WM 11643
VH-AV reusable suction hose	WM 10662
FT-AV fingertip control for reusable suction hose	WM 10666
ACCUVAC Pro/ACCUVAC Lite instructions for use EN	WM 68161

ACCUVAC Pro with reusable canister system and power supply unit and charger for 100–240 V **WM 11630**

Designation	Article number
ACCUVAC Pro	WM 11602
Rechargeable battery, lithium-ion	WM 11603
Battery compartment cover	WM 11604
Reusable canister system, 1000 ml, with canister holder	WM 11643
VH-AV reusable suction hose	WM 10662
FT-AV fingertip control for reusable suction hose	WM 10666
Power supply unit and charger	WM 2620
ACCUVAC Pro/ACCUVAC Lite instructions for use EN	WM 68161

ACCUVAC Pro with reusable canister system and accessories bag **WM 11640**

Designation	Article number
ACCUVAC Pro	WM 11602
Rechargeable battery, lithium-ion	WM 11603
Battery compartment cover for accessories bag	WM 11614
Reusable canister system, 1000 ml, with canister holder	WM 11643
VH-AV reusable suction hose	WM 10662
FT-AV fingertip control for reusable suction hose	WM 10666
Accessories bag	WM 11690
ACCUVAC Pro/ACCUVAC Lite instructions for use EN	WM 68161

ACCUVAC Pro with accessories **WM 11650**

Designation	Article number
ACCUVAC Pro	WM 11602
Rechargeable battery, lithium-ion	WM 11603
Battery compartment cover	WM 11604
Reusable canister system, 1000 ml, with canister holder	WM 11643
VH-AV reusable suction hose	WM 10662
FT-AV fingertip control for reusable suction hose	WM 10666
Wall mounting	WM 15208
Holding plate for equipment rail	WM 15845
Set of 2, retaining claw for fastening to equipment rail	WM 15805
Power supply unit and charger	WM 2620

Designation	Article number
Shoulder strap	WM 11693
Conversion kit, accessories bag	WM 17829
Conversion kit, Serres disposable canister system, 1000 ml	WM 17825
comprising:	
Holder for disposable canister system	WM 11754
Vacuum tube for disposable canister system	WM 11761
Serres secretions canister, 1000 ml	WM 10775
Suction hose with fingertip control	WM 10778
Set of 32, Serres suction bag, 1000 ml, with bacteria filter and solidifying agent	WM 17800
Set of 10, bacteria filter for reusable secretions canister	WM 17830
Set of 10, suction hose for disposable canister system	WM 15935
comprising:	
Suction hose with fingertip control	WM 10778
12 V connection cable	WM 10650
ACCUVAC Pro/ACCUVAC Lite instructions for use EN	WM 68161

11.2.2 Standard scope of supply ACCUVAC Lite

ACCUVAC Lite without canister system

WM 11701

Designation	Article number
ACCUVAC Lite	WM 11702
Lead battery	WM 10747
Battery compartment cover	WM 11704
ACCUVAC Pro/ACCUVAC Lite instructions for use EN	WM 68161

ACCUVAC Lite with disposable canister system WM 11705

Designation	Article number
ACCUVAC Lite	WM 11702
Lead battery	WM 10747
Battery compartment cover	WM 11704
Holder for disposable canister system	WM 11754
Vacuum tube for disposable canister system	WM 11761
Serres secretions canister, 1000 ml	WM 10775
Suction hose with fingertip control	WM 10778
Serres suction bag, 1000 ml, with bacteria filter and solidifying agent	WM 10774
ACCUVAC Pro/ACCUVAC Lite instructions for use EN	WM 68161

ACCUVAC Lite with disposable canister system and power supply unit and charger for 100–240 V WM 11735

Designation	Article number
ACCUVAC Lite	WM 11702
Lead battery	WM 10747
Battery compartment cover	WM 11704
Holder for disposable canister system	WM 11754
Vacuum tube for disposable canister system	WM 11761
Serres secretions canister, 1000 ml	WM 10775
Suction hose with fingertip control	WM 10778
Serres suction bag, 1000 ml, with bacteria filter and solidifying agent	WM 10774
Power supply unit and charger	WM 2620
ACCUVAC Pro/ACCUVAC Lite instructions for use EN	WM 68161

ACCUVAC Lite with disposable canister system and accessories bag WM 11745

Designation	Article number
ACCUVAC Lite	WM 11702
Lead battery	WM 10747
Battery compartment cover for accessories bag	WM 11714
Holder for disposable canister system	WM 11754
Vacuum tube for disposable canister system	WM 11761

Designation	Article number
Serres secretions canister, 1000 ml	WM 10775
Suction hose with fingertip control	WM 10778
Serres suction bag, 1000 ml, with bacteria filter and solidifying agent	WM 10774
Power supply unit and charger	WM 2620
Accessories bag	WM 11690
ACCUVAC Pro/ACCUVAC Lite instructions for use EN	WM 68161

ACCUVAC Lite with reusable canister system**WM 11700**

Designation	Article number
ACCUVAC Lite	WM 11702
Lead battery	WM 10747
Battery compartment cover ACCUVAC Lite	WM 11704
Reusable canister system, 1000 ml, with canister holder	WM 11643
VH-AV reusable suction hose	WM 10662
FT-AV fingertip control for reusable suction hose	WM 10666
ACCUVAC Pro/ACCUVAC Lite instructions for use EN	WM 68161

ACCUVAC Lite with reusable canister system and power supply unit and charger for 100–240 V**WM 11730**

Designation	Article number
ACCUVAC Lite	WM 11702
Lead battery	WM 10747
Battery compartment cover	WM 11704
Reusable canister system, 1000 ml, with canister holder	WM 11643
VH-AV reusable suction hose	WM 10662
FT-AV fingertip control for reusable suction hose	WM 10666
Power supply unit and charger	WM 2620
ACCUVAC Pro/ACCUVAC Lite instructions for use EN	WM 68161

ACCUVAC Lite with reusable canister system and accessories bag **WM 11740**

Designation	Article number
ACCUVAC Lite	WM 11702
Lead battery	WM 10747
Battery compartment cover for accessories bag	WM 11714
Reusable canister system, 1000 ml, with canister holder	WM 11643
VH-AV reusable suction hose	WM 10662
FT-AV fingertip control for reusable suction hose	WM 10666
Accessories bag	WM 11690
ACCUVAC Pro/ACCUVAC Lite instructions for use EN	WM 68161

11.2.3 Accessories and other parts

A current list of accessories is available at www.weinmann-emergency.com or from your authorized dealer.

Designation	Additional information	Article number
Power supply		
12 V connection cable	ACCUVAC Pro, ACCUVAC Lite	WM 10650
12 volt connection cable for ACCUVAC with red adapter ring (for cigarette lighter socket)	ACCUVAC Pro, ACCUVAC Lite	WM 10950
Power supply unit and charger	ACCUVAC Pro, ACCUVAC Lite	WM 2620
Rechargeable battery, lithium-ion	ACCUVAC Pro	WM 11603
Lead battery	ACCUVAC Lite	WM 10747
Fastening		
Wall mounting	ACCUVAC Pro, ACCUVAC Lite	WM 15208
Wall mounting for power supply unit and charger	ACCUVAC Pro, ACCUVAC Lite	WM 15844
Holding plate for equipment rail	ACCUVAC Pro, ACCUVAC Lite	WM 15845
Kit, retaining claw for fastening to equipment rail	–	WM 15795

Designation	Additional information	Article number
Set of 2, retaining claw for fastening to equipment rail	–	WM 15805
Kit, pole mounting Ø 19-40 mm	–	WM 15806
Device base	ACCUVAC Pro, ACCUVAC Lite	WM 11677
Suction hose reel	ACCUVAC Pro, ACCUVAC Lite	WM 11664
Reusable canister system		
Kit, reusable canister system	ACCUVAC Pro, ACCUVAC Lite	WM 17821
comprising:		
Secretions canister with cover, 1000 ml	ACCUVAC Pro, ACCUVAC Lite	WM 11642
VH-AV reusable suction hose	ACCUVAC Pro, ACCUVAC Lite	WM 10662
FT-AV fingertip control for reusable suction hose	ACCUVAC Pro, ACCUVAC Lite	WM 10666
Conversion kit, reusable canister system		
Conversion kit, reusable canister system	ACCUVAC Pro, ACCUVAC Lite	WM 17820
comprising:		
Kit, reusable canister system	ACCUVAC Pro, ACCUVAC Lite	WM 17821
Holder for reusable canister system	ACCUVAC Pro, ACCUVAC Lite	WM 11654
Bacteria filter for reusable secretions canister		
Bacteria filter for reusable secretions canister	ACCUVAC Pro, ACCUVAC Lite	WM 11659
Set of 10, VH-AV reusable suction hose	ACCUVAC Pro, ACCUVAC Lite	WM 15307
Set of 20, VH-AV reusable suction hose	ACCUVAC Pro, ACCUVAC Lite	WM 15308
Set of 50, VH-AV reusable suction hose	ACCUVAC Pro, ACCUVAC Lite	WM 15309
Set of 10, bacteria filter for reusable secretions canister	ACCUVAC Pro, ACCUVAC Lite	WM 17830
Reusable secretions canister 1000 ml	ACCUVAC Pro, ACCUVAC Lite	WM 11653

Designation	Additional information	Article number
Float ball for reusable secretions canister	ACCUVAC Pro, ACCUVAC Lite	WM 11662
Filter holder for reusable secretions canister	ACCUVAC Pro, ACCUVAC Lite	WM 11661
O-ring for filter holder	ACCUVAC Pro, ACCUVAC Lite	WM 11663
VH-AV reusable suction hose	ACCUVAC Pro, ACCUVAC Lite	WM 10662
Set of 10, FT-AV fingertip control for reusable suction hose		
comprising:	–	WM 15324
FT-AV fingertip control for reusable suction hose	ACCUVAC Pro, ACCUVAC Lite	WM 10666
Set of 20, FT-AV fingertip control for reusable suction hose		
comprising:	–	WM 15325
FT-AV fingertip control for reusable suction hose	ACCUVAC Pro, ACCUVAC Lite	WM 10666
Set of 50, FT-AV fingertip control for reusable suction hose		
comprising:	–	WM 15326
FT-AV fingertip control for reusable suction hose	ACCUVAC Pro, ACCUVAC Lite	WM 10666
FT-AV fingertip control for reusable suction hose	ACCUVAC Pro, ACCUVAC Lite	WM 10666
Disposable canister system		
Kit, disposable canister system	ACCUVAC Pro, ACCUVAC Lite	WM 17826
comprising:		
Vacuum tube for disposable canister system	ACCUVAC Pro, ACCUVAC Lite	WM 11761
Serres secretions canister, 1000 ml	ACCUVAC Pro, ACCUVAC Lite	WM 10775

Designation	Additional information	Article number
Suction hose with fingertip control	ACCUVAC Pro, ACCUVAC Lite	WM 10778
Conversion kit, Serres disposable canister system, 1000 ml	ACCUVAC Pro, ACCUVAC Lite	WM 17825
comprising:		
Holder for disposable canister system	ACCUVAC Pro, ACCUVAC Lite	WM 11754
Vacuum tube for disposable canister system	ACCUVAC Pro, ACCUVAC Lite	WM 11761
Kit, Serres secretions canister	ACCUVAC Pro, ACCUVAC Lite	WM 10790
comprising:		
Serres secretions canister, 1000 ml	ACCUVAC Pro, ACCUVAC Lite	WM 10775
Suction hose with fingertip control	ACCUVAC Pro, ACCUVAC Lite	WM 10778
Set of 32, Serres suction bag, 1000 ml, with bacteria filter and solidifying agent	ACCUVAC Pro, ACCUVAC Lite	WM 17800
Set of 20, suction hose for disposable canister system	–	WM 15936
comprising:		
Suction hose with fingertip control	ACCUVAC Pro, ACCUVAC Lite	WM 10778
Set of 32, suction hose for disposable canister system	–	WM 10815
comprising:		
Suction hose with fingertip control	ACCUVAC Pro, ACCUVAC Lite	WM 10778
Set of 50, suction hose for disposable canister system	–	WM 15937
comprising:		
Suction hose with fingertip control	ACCUVAC Pro, ACCUVAC Lite	WM 10778

Designation	Additional information	Article number
Suction hose with fingertip control	ACCUVAC Pro, ACCUVAC Lite	WM 10778
Set of 10, hygiene filter for disposable canister system comprising:	ACCUVAC Pro, ACCUVAC Lite	WM 11634
Hygiene filter for disposable canister system	ACCUVAC Pro, ACCUVAC Lite	WM 11626
Hose, silicone, 7x3, 30 mm	ACCUVAC Pro, ACCUVAC Lite	WM 11644
Angled connector for Serres secretions canister	ACCUVAC Pro, ACCUVAC Lite	WM 10799
Float ball for reusable secretions canister	ACCUVAC Pro, ACCUVAC Lite	WM 11662
Protection, carrying comfort and storage		
Shoulder strap	ACCUVAC Pro, ACCUVAC Lite	WM 11693
Protective bag	ACCUVAC Pro, ACCUVAC Lite	WM 11692
Battery compartment cover	ACCUVAC Pro	WM 11604
Battery compartment cover	ACCUVAC Lite	WM 11704
Conversion kit, accessories bag comprising:	ACCUVAC Pro	WM 17829
Accessories bag	ACCUVAC Pro, ACCUVAC Lite	WM 11690
Battery compartment cover for accessories bag	ACCUVAC Pro	WM 11614
Conversion kit, accessories bag comprising:	ACCUVAC Lite	WM 17839
Accessories bag	ACCUVAC Pro, ACCUVAC Lite	WM 11690
Battery compartment cover for accessories bag	ACCUVAC Lite	WM 11714

Designation	Additional information	Article number
Other		
Kit, release catch	ACCUVAC Pro	WM 17827
comprising:		
Release catch, red	ACCUVAC Pro	
Spring for release catch	ACCUVAC Pro, ACCUVAC Lite	
Kit, release catch	ACCUVAC Lite	WM 17837
comprising:		
Release catch, gray	ACCUVAC Lite	
Spring for release catch	ACCUVAC Pro, ACCUVAC Lite	
Elbow for device inlet	ACCUVAC Pro, ACCUVAC Lite	WM 10798
Kit, secretions canister cover	ACCUVAC Pro, ACCUVAC Lite	WM 17822
comprising:		
Upper section of secretions canister cover	ACCUVAC Pro, ACCUVAC Lite	WM 11657
Cap for adjusting knob	ACCUVAC Lite	WM 11724

11.3 Warranty

Starting from the date of purchase, WEINMANN Emergency offers the customer a limited warranty on a new original WEINMANN Emergency product or spare parts installed by WEINMANN Emergency in accordance with applicable warranty terms and conditions for the particular product and the warranty periods listed below. The warranty terms and conditions are available on the Internet at www.weinmann-emergency.com. On request, we will send you the warranty terms and conditions by mail.

If you wish to make a warranty claim, consult your authorized dealer.

Product	Warranty periods
WEINMANN Emergency-devices, incl. accessories (excluding: masks) for oxygen therapy and emergency medicine	2 years
Masks, incl. accessories, rechargeable batteries, batteries (unless otherwise stated in the technical documentation), sensors, hoses/tubes	6 months
Disposable products	None

11.4 Declaration of conformity

The manufacturer, ATMOS MedizinTechnik GmbH & Co. KG, Lenzkirch, Germany, declares herewith that the product complies fully with the relevant regulations of Medical Device Directive 93/42/EEC and Directive 2011/65/EU (RoHS II).

The full declaration of conformity from the manufacturer can be found on our website at: www.weinmann-emergency.com.

Designed by

WEINMANN Emergency
Medical Technology GmbH + Co. KG
Frohbösestraße 12
22525 Hamburg
GERMANY
T: +49 40 88 18 96-120
E: customerservice@weinmann-emt.de

Manufacturer

ATMOS MedizinTechnik GmbH & Co. KG
Ludwig-Kegel-Straße 16
79853 Lenzkirch
GERMANY

CE 0124